

TEST REPORT
IEC 60950-1 and/or EN60950-1
Information technology equipment – Safety –
Part 1: General requirements

Report Number: S83780.03_V1
Date of issue.....: 27/05/2013
Total number of pages 100

Testing Laboratory: I.T.L. (PRODUCT TESTING) Ltd.
Address: 1 Bat-Sheva St. POB 87 Lod 71100 ISRAEL

Applicant's name: Pointer Telocation Ltd.
Address: 14 Hamelacha St., Rosh Ha'ayin 48091, Israel

Manufacturer's name.....: Pointer Telocation Ltd.
Address: 14 Hamelacha St., Rosh Ha'ayin 48091, Israel

Test specification:
Standard: EN 60950-1:2006+A11:2009+A1:2010+A12:2011+AC:2011
Test procedure: PM120
Non-standard test method.....: N/A

Test Report Form No.....: IEC60950_1C
Test Report Form(s) Originator: SGS Fimko Ltd
Master TRF.....: Dated 2012-08

Copyright © 2012 Worldwide System for Conformity Testing and Certification of Electrotechnical Equipment and Components (IECEE), Geneva, Switzerland. All rights reserved.

This publication may be reproduced in whole or in part for non-commercial purposes as long as the IECEE is acknowledged as copyright owner and source of the material. IECEE takes no responsibility for and will not assume liability for damages resulting from the reader's interpretation of the reproduced material due to its placement and context.

If this Test Report Form is used by non-IECEE members, the IECEE/IEC logo and the reference to the CB Scheme procedure shall be removed.

This report is not valid as a CB Test Report unless signed by an approved CB Testing Laboratory and appended to a CB Test Certificate issued by an NCB in accordance with IECEE 02.

Test item description	Vehicle security and location system
Trade Mark	Cellocator
Manufacturer	Pointer Telocation Ltd
Model/Type reference.....	CelloTrack3G Power; CelloTrack3G Lighter; CelloTrack3G IP67; CelloTrack3G Power 6M; CelloTrack3G 6M; CelloTrack3G XT; CelloTrack3G Power XT; CelloTrack Lighter 6M.
Ratings	No direct connection to mains ,Class III. (9-32Vdc,0.6A or internally rechargeable battery)

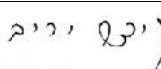

Testing procedure and testing location:		
<input checked="" type="checkbox"/>	Testing Laboratory:	I.T.L. (PRODUCT TESTING) Ltd.
Testing location/ address		1 Bat-Sheva St. POB 87 Lod 71100 ISRAEL
<input type="checkbox"/>	Associated CB Laboratory:	
Testing location/ address		
Tested by (name + signature)		Yigal Y Cohen 
Approved by (name + signature)		Yariv Keidar 
<input type="checkbox"/>	Testing procedure: TMP	
Testing location/ address		
Tested by (name + signature)		
Approved by (name + signature)		
<input type="checkbox"/>	Testing procedure: WMT	
Testing location/ address		
Tested by (name + signature)		
Witnessed by (name + signature)		
Approved by (name + signature)		
<input type="checkbox"/>	Testing procedure: SMT	
Testing location/ address		
Tested by (name + signature)		
Approved by (name + signature)		
Supervised by (name + signature)		
<input type="checkbox"/>	Testing procedure: RMT	
Testing location/ address		
Tested by (name + signature)		
Approved by (name + signature)		
Supervised by (name + signature)		



List of Attachments (including a total number of pages in each attachment):

Appendix 1 – Photographs

Appendix 2 – National differences

<p>Summary of testing:</p> <p>This report is updating to ITL report reference S83780.02 with the following main modifications:</p> <p>Upgraded standard version.</p> <p>Tests were taken from ITL reference report R83780.02 dated on 22 may 2012 Cello Track Power</p>	
<p>Tests performed (name of test and test clause):</p> <p>-S83870.03- No tests</p> <p>-R83780.02- 1.6.2. Input test 1.7.11. Marking Durability test 2.1.1.8 Capacitance Discharge – DC mains 4.2. Mechanical strength test 4.3.8. Battery test 4.5.1. Heating test 5.3. Abnormal operation and fault conditions tests</p> <p>R83780.01 1.6.2. Input test 1.7.11. Marking Durability test 4.2. Mechanical strength test 4.3.8. Battery test 4.5.1. Heating test 5.3. Abnormal operation and fault conditions tests</p> <p>Unit was tested for ambient of up to 45°C.</p>	<p>Testing location:</p> <p>I.T.L. (PRODUCT TESTING) Ltd. 1 Bat-Sheva St. POB 87 Lod 71100 ISRAEL</p>



Summary of compliance with National Differences

Summary of compliance with National Differences to IEC 60950-1:2005 (2nd Edition)+Am 1:2009.

List of countries addressed:

EU Group Differences, EU Special National Conditions, AT, BE, , CZ, DE, DK, ES, FI, FR, HU ITNLSE, SI, PL, SK, UK

Explanation of used codes: AU=Australia, AT=Austria, BE=Belgium, CH=Switzerland, CZ=Czech Republic, DE=Germany, DK=Denmark, ES=Spain, FI=Finland, FR=France, HU=Hungary, IT=Italy, , NL=The Netherlands, SE=Sweden, SI=Slovenia, PL=Poland, SK=Slovakia, UK=United Kingdom,

The product fulfils the requirements of IEC 60950-1:2005 (Second Edition), Am 1: 2009, EN 60950-1:2006+A11:2009+A1:2010, EN 60950-1:2006+A11:2009+A1:2010+A12:2011 and EN 60950-1:2006+A11:2009.

Copy of marking plate



351465

C/N:GE9730001-000
CelloTrack Power
IMEI:357004030198858
SW:28y
Made in Israel



Cellocator



Jan.2012



351465

C/N:GE9730005-000
CelloTrack Lighter
IMEI:357004030198858
SW:28y
Made in Israel



Cellocator



Jan.2012



351465

C/N:GE9730012-000
CelloTrack IP67
IMEI:357004030198858
SW:28y
Made in Israel



Cellocator



Jan.2012



351465

C/N:GE9730021-000
CelloTrack Power 6M
IMEI:357004030198858
SW:28y
Made in Israel



Cellocator



Jan.2012



351465

C/N:GE9730022-000
CelloTrack 6M
IMEI:357004030198858
SW:28y
Made in Israel



Cellocator



Jan.2012



351465

C/N:GE9730023-000
CelloTrack Lighter 6M
IMEI:357004030198858
SW:28y
Made in Israel



Cellocator



Jan.2012



351465

C/N:GE9730025-000
CelloTrack XT
IMEI:357004030198858
SW:28y
Made in Israel



Cellocator



Jan.2012



351465

C/N:GE9730026-000
CelloTrack Power XT
IMEI:357004030198858
SW:28y
Made in Israel



Cellocator



Jan.2012

Copy of marking plate:

P/N:GT9740001-000  Dec.2012  
CelloTrack3G Power 9.32V --- 0.6A
 S/N:  000000444444
 FCCID: R17HE910NA IC ID: 5131A-HE910NA
 IMEI:  *353836050019769*
 Made in Israel

P/N:GT9740005-000  Dec.2012  
CelloTrack3G Lighter 9.32V --- 0.6A
 S/N:  000000444444
 FCCID: R17HE910NA IC ID: 5131A-HE910NA
 IMEI:  *353836050019769*
 Made in Israel

P/N:GT9740012-000  Dec.2012  
CelloTrack3G IP67 4.2V --- 0.6A
 S/N:  000000444444
 FCCID: R17HE910NA IC ID: 5131A-HE910NA
 IMEI:  *353836050019769*
 Made in Israel

P/N:GT9740021-000  Dec.2012  
CelloTrack3G Power 6M 9.32V --- 0.6A
 S/N:  000000444444
 FCCID: R17HE910NA IC ID: 5131A-HE910NA
 IMEI:  *353836050019769*
 Made in Israel

P/N:GT9740022-000  Dec.2012  
CelloTrack3G 6M 4.2V --- 0.6A
 S/N:  000000444444
 FCCID: R17HE910NA IC ID: 5131A-HE910NA
 IMEI:  *353836050019769*
 Made in Israel

P/N:GT9740025-000  Dec.2012  
CelloTrack3G XT 4.2V --- 0.6A
 S/N:  000000444444
 FCCID: R17HE910NA IC ID: 5131A-HE910NA
 IMEI:  *353836050019769*
 Made in Israel

P/N:GT9740026-000  Dec.2012  
CelloTrack3G Power XT 9.32V --- 0.6A
 S/N:  000000444444
 FCCID: R17HE910NA IC ID: 5131A-HE910NA
 IMEI:  *353836050019769*
 Made in Israel



Test item particulars:	
Equipment mobility.....:	<input type="checkbox"/> movable <input type="checkbox"/> hand-held <input type="checkbox"/> transportable <input checked="" type="checkbox"/> stationary <input type="checkbox"/> for building-in <input type="checkbox"/> direct plug-in
Connection to the mains	<input type="checkbox"/> pluggable equipment <input type="checkbox"/> type A <input type="checkbox"/> type B <input checked="" type="checkbox"/> permanent connection <input type="checkbox"/> detachable power supply cord <input type="checkbox"/> non-detachable power supply cord <input checked="" type="checkbox"/> not directly connected to the mains
Operating condition.....:	<input checked="" type="checkbox"/> continuous <input type="checkbox"/> rated operating / resting time:
Access location	<input checked="" type="checkbox"/> operator accessible <input type="checkbox"/> restricted access location
Over voltage category (OVC)	<input type="checkbox"/> OVC I <input type="checkbox"/> OVC II <input type="checkbox"/> OVC III <input type="checkbox"/> OVC IV <input checked="" type="checkbox"/> other: Class III
Mains supply tolerance (%) or absolute mains supply values	
Tested for IT power systems	<input type="checkbox"/> Yes <input checked="" type="checkbox"/> No
IT testing, phase-phase voltage (V)	
Class of equipment	<input type="checkbox"/> Class I <input type="checkbox"/> Class II <input checked="" type="checkbox"/> Class III <input type="checkbox"/> Not classified
Considered current rating of protective device as part of the building installation (A)	Class III
Pollution degree (PD)	<input type="checkbox"/> PD 1 <input checked="" type="checkbox"/> PD 2 <input type="checkbox"/> PD 3
IP protection class	IPX0
Altitude during operation (m)	Up to 2000m
Altitude of test laboratory (m)	50m
Mass of equipment (kg)	0.35Kg
Possible test case verdicts:	
- test case does not apply to the test object	: N/A
- test object does meet the requirement.....	: P (Pass)
- test object does not meet the requirement.....	: F (Fail)
Testing:	
Date of receipt of test item	: 02/01/2013
Date(s) of performance of tests	: S83780.01: 1 June 2009 to 17 June 2009 S83780.02: 13 May 2012 to 17 May 2012



General remarks:

The test results presented in this report relate only to the object tested.
This report shall not be reproduced, except in full, without the written approval of the Issuing testing laboratory.

"(see Enclosure #)" refers to additional information appended to the report.

"(see appended table)" refers to a table appended to the report.

Throughout this report a comma / point is used as the decimal separator.

Manufacturer's Declaration per sub-clause 6.2.5 of IEC60950-1:

The application for obtaining a CB Test Certificate includes more than one factory location and a declaration from the Manufacturer stating that the sample(s) submitted for evaluation is (are) representative of the products from each factory has been provided.....: Yes Not applicable

When differences exist; they shall be identified in the General product information section.

Name and address of factory (ies) : Pointer Telocation Ltd.
14 Hamelacha St., Rosh Ha'ayin 48091, Israel

General product information:

EUT is a vehicle security and location system. Unit is Class III equipment and contains plastic enclosure, SELV circuits and rechargeable battery (4 types). Unit is considered LPS powered. When vehicle battery powered, LPS is provided by certified PTC at power input having Itrip 2.2A. When internal battery powered LPS is provided by certified PTC at battery pack output having Itrip 3.2A.

There are two options of EUT:

Option 1 – unit installed in a vehicle and powered from vehicle power 9-32Vdc.

Option 2 – internally powered unit with rechargeable battery. Battery is charged with charger having output 4.2Vdc up to 2.7A, approved according to EN60950-1 and which is not part of this investigation.

All input/outputs ports are considered as signal ones for connection to sensors and for controlling via discrete open-collector outputs. All interfaces are considered as SELV.

Both options are identical from safety point of view with the same power consumption.

Manual shall contain the following sentences:

"Caution. Risk of explosion if battery is replaced by an incorrect type. Dispose of used batteries according to the instructions".



Product Name	Model Differences:		
CelloTrack	no charger assembled on PCB- with max capacity of 13.6A/H battery		
CelloTrack Power	with charger-with max capacity of 13.6A/H battery (Full configuration)		
CelloTrack Lighter	Same as CelloTrack Power - Car application		
CelloTrack 6M	Same as CelloTrack Power, no charger assembled on PCB -2A/H battery		
CelloTrack Power 6M	Same as CelloTrack Power, with charger-2A/H battery		
CelloTrack Lighter 6M	Same as CelloTrack Power 6M - Car application		
CelloTrack XT	Same as CelloTrack Power, no charger assembled on PCB - 4.252A/H battery		
CelloTrack Power XT	Same as CelloTrack Power, with charger-4.252A/H battery		
Attachment - 20091109-1038 –IP67 test report done by Qualitech			
Report History:			
R83780.01 – Original Report.			
R83780.02 - Update of report. Added two rechargeable batteries for testing: GP Model No. NTRLO1801004 and YOKU Model No. 064080			
S83780.03- Upgraded standard version ,Alternate rechargeable battery, Cellular modem was changed to 3G including the Microprocessor			
Alternate rechargeable battery including battery charger circuit			
Alternate PTC on power circuit			
Cellular modem was changed to 3G including the Microprocessor ,DC/DC MP2562DQ ,output driver BTS3405G and peripherals components			
Abbreviations used in the report:			
- normal conditions	N.C.	- single fault conditions	S.F.C
- functional insulation	OP	- basic insulation	BI
- double insulation	DI	- supplementary insulation SI	
- between parts of opposite polarity	BOP	- reinforced insulation	RI
Indicate used abbreviations (if any)			



1	GENERAL		P
1.5	Components		P
1.5.1	General	Product is class III	P
	Comply with IEC 60950-1 or relevant component standard	(see appended tables 1.5.1)	P
1.5.2	Evaluation and testing of components	<p>Certified components are used in accordance with their ratings, certifications and they comply with applicable parts of this Standard.</p> <p>Components not certified are used in accordance with their ratings and they comply with applicable parts of IEC 60950 and the relevant component Standard.</p> <p>Components, for which no relevant IEC-Standard exists, have been tested under the conditions occurring in the equipment, using applicable parts of IEC 60950.</p>	P
1.5.3	Thermal controls		N/A
1.5.4	Transformers	Class III	N/A
1.5.5	Interconnecting cables	No part of the units	N/A
1.5.6	Capacitors bridging insulation	Class III	N/A
1.5.7	Resistors bridging insulation	Class III	N/A
1.5.7.1	Resistors bridging functional, basic or supplementary insulation		N/A
1.5.7.2	Resistors bridging double or reinforced insulation between a.c. mains and other circuits		N/A
1.5.7.3	Resistors bridging double or reinforced insulation between a.c. mains and antenna or coaxial cable		N/A
1.5.8	Components in equipment for IT power systems	Class III	N/A
1.5.9	Surge suppressors	Class III	N/A
1.5.9.1	General		N/A
1.5.9.2	Protection of VDRs		N/A
1.5.9.3	Bridging of functional insulation by a VDR		N/A
1.5.9.4	Bridging of basic insulation by a VDR		N/A
1.5.9.5	Bridging of supplementary, double or reinforced insulation by a VDR		N/A
1.6	Power interface		P

1.6.1	AC power distribution systems	Class III	N/A
1.6.2	Input current	Class III- No connection to mains (see appended table 1.6.2)	P
1.6.3	Voltage limit of hand-held equipment		N/A
1.6.4	Neutral conductor		N/A

1.7	Marking and instructions		P
1.7.1	Power rating and identification markings	Identification label, power rating marking is provided	P
1.7.1.1	Power rating marking		P
	Multiple mains supply connections.....:	Class III	N/A
	Rated voltage(s) or voltage range(s) (V)	Provided	P
	Symbol for nature of supply, for d.c. only	Provided	P
	Rated frequency or rated frequency range (Hz)	Class III	N/A
	Rated current (mA or A)	Provided	P
1.7.1.2	Identification markings		P
	Manufacturer's name or trade-mark or identification mark	Provided	P
	Model identification or type reference	Provided	P
	Symbol for Class II equipment only		N/A
	Other markings and symbols		N/A
1.7.2	Safety instructions and marking	Relevant instructions are provided	P
1.7.2.1	General		P
1.7.2.2	Disconnect devices	Class III	N/A
1.7.2.3	Overcurrent protective device	Provided	P
1.7.2.4	IT power distribution systems		N/A
1.7.2.5	Operator access with a tool		N/A
1.7.2.6	Ozone		N/A
1.7.3	Short duty cycles	Continuous operation	N/A
1.7.4	Supply voltage adjustment	The unit is supported range 9-32Vdc without adjustment	N/A
	Methods and means of adjustment; reference to installation instructions		N/A
1.7.5	Power outlets on the equipment		N/A
1.7.6	Fuse identification (marking, special fusing characteristics, cross-reference)	Class III Marking is provided is in a relevant documents	P
1.7.7	Wiring terminals	No terminals	N/A



1.7.7.1	Protective earthing and bonding terminals	Unit Class III	N/A
1.7.7.2	Terminals for a.c. mains supply conductors	No such terminals	N/A
1.7.7.3	Terminals for d.c. mains supply conductors	No such terminals	N/A
1.7.8	Controls and indicators	There are no controls affecting safety.	N/A
1.7.8.1	Identification, location and marking	There are no safety related controls	N/A
1.7.8.2	Colours	There are no power outlets.	N/A
1.7.8.3	Symbols according to IEC 60417	No symbols	N/A
1.7.8.4	Markings using figures	Figures are not used for indicating different positions of controls	N/A
1.7.9	Isolation of multiple power sources	No multiple power sources	N/A
1.7.10	Thermostats and other regulating devices	No such devices	N/A
1.7.11	Durability	The marking(s) withstood the required test	P
1.7.12	Removable parts	No removable parts	N/A
1.7.13	Replaceable batteries	Battery is not replaceable	N/A
	Language(s)		—
1.7.14	Equipment for restricted access locations.....	Unit is not intended for Restricted access location.	N/A

2	PROTECTION FROM HAZARDS		P
2.1	Protection from electric shock and energy hazards		P
2.1.1	Protection in operator access areas	Class III	P
2.1.1.1	Access to energized parts		P
	Test by inspection		P
	Test with test finger (Figure 2A)		P
	Test with test pin (Figure 2B)		P
	Test with test probe (Figure 2C)	No TNV internal circuits	N/A
2.1.1.2	Battery compartments		N/A
2.1.1.3	Access to ELV wiring	Class III	N/A
	Working voltage (V _{peak} or V _{rms}); minimum distance through insulation (mm)	(see appended tables 2.10.2 and 2.10.5)	—
2.1.1.4	Access to hazardous voltage circuit wiring	No hazardous voltages	N/A
2.1.1.5	Energy hazards	No operator accessible hazardous energy	P
2.1.1.6	Manual controls	No manual controls	N/A
2.1.1.7	Discharge of capacitors in equipment	SELV powered unit	N/A
	Measured voltage (V); time-constant (s)		—

2.1.1.8	Energy hazards – d.c. mains supply	Class III	N/A
	a) Capacitor connected to the d.c. mains supply .. :		N/A
	b) Internal battery connected to the d.c. mains supply .. :		N/A
2.1.1.9	Audio amplifiers .. :	No audio amplifiers	N/A
2.1.2	Protection in service access areas	Unit is not intended to be serviced while operating	N/A
2.1.3	Protection in restricted access locations	Unit is not for RAL	N/A

2.2	SELV circuits		P
2.2.1	General requirements	Unit is powered by SELV voltages	P
2.2.2	Voltages under normal conditions (V) .. :	Max. 32VDC/pk	P
2.2.3	Voltages under fault conditions (V) .. :	Do not exceed SELV levels	N/A
2.2.4	Connection of SELV circuits to other circuits .. :	SELV circuits are connected to SELV circuits.	P

2.3	TNV circuits		N/A
2.3.1	Limits	No TNV circuits	N/A
	Type of TNV circuits..... :		—
2.3.2	Separation from other circuits and from accessible parts		N/A
2.3.2.1	General requirements		N/A
2.3.2.2	Protection by basic insulation		N/A
2.3.2.3	Protection by earthing		N/A
2.3.2.4	Protection by other constructions .. :		N/A
2.3.3	Separation from hazardous voltages		N/A
	Insulation employed .. :		—
2.3.4	Connection of TNV circuits to other circuits		N/A
	Insulation employed .. :		—
2.3.5	Test for operating voltages generated externally		N/A

2.4	Limited current circuits		N/A
2.4.1	General requirements	No investigated for limited current circuits	N/A
2.4.2	Limit values		N/A
	Frequency (Hz)..... :		—
	Measured current (mA) .. :		—
	Measured voltage (V) .. :		—
	Measured circuit capacitance (nF or μ F) .. :		—

2.4.3	Connection of limited current circuits to other circuits		N/A
-------	--	--	-----

2.5	Limited power sources		P
	a) Inherently limited output	Signal/data ports not associated with power transfer were evaluated as such	P
	b) Impedance limited output	Input power circuit of EUT with approved PTC rated 2.2A Itrip, and battery pack with PTC at output having Itrip 3.2A regarded as LPS -32VDC input: I trip of the PTC: 2.2A, Uoc max. 32VDC, Pmax. 70.4VA Battery pack, Thinking Electronic Industrial: Uoc max. 4.2VDC, Itrip of the PTC 3.2A, Pmax. 13.44VA	P
	c) Regulating network limited output under normal operating and single fault condition		N/A
	d) Overcurrent protective device limited output		N/A
	Max. output voltage (V), max. output current (A), max. apparent power (VA)		—
	Current rating of overcurrent protective device (A) .:		—
	Use of integrated circuit (IC) current limiters		

2.6	Provisions for earthing and bonding		N/A
2.6.1	Protective earthing	Class III equipment No connection to earthing	N/A
2.6.2	Functional earthing		N/A
2.6.3	Protective earthing and protective bonding conductors		N/A
2.6.3.1	General	Class III equipment	N/A
2.6.3.2	Size of protective earthing conductors		N/A
	Rated current (A), cross-sectional area (mm ²), AWG		—
2.6.3.3	Size of protective bonding conductors		N/A
	Rated current (A), cross-sectional area (mm ²), AWG		—
	Protective current rating (A), cross-sectional area (mm ²), AWG.....		



2.6.3.4	Resistance of earthing conductors and their terminations; resistance (Ω), voltage drop (V), test current (A), duration (min)		N/A
2.6.3.5	Colour of insulation		N/A
2.6.4	Terminals	Class III equipment	N/A
2.6.4.1	General		N/A
2.6.4.2	Protective earthing and bonding terminals		N/A
	Rated current (A), type, nominal thread diameter (mm).....		—
2.6.4.3	Separation of the protective earthing conductor from protective bonding conductors		N/A
2.6.5	Integrity of protective earthing	Class III equipment No connection to earthing	N/A
2.6.5.1	Interconnection of equipment		N/A
2.6.5.2	Components in protective earthing conductors and protective bonding conductors		N/A
2.6.5.3	Disconnection of protective earth		N/A
2.6.5.4	Parts that can be removed by an operator		N/A
2.6.5.5	Parts removed during servicing		N/A
2.6.5.6	Corrosion resistance		N/A
2.6.5.7	Screws for protective bonding		N/A
2.6.5.8	Reliance on telecommunication network or cable distribution system		N/A

2.7	Overcurrent and earth fault protection in primary circuits		N/A
2.7.1	Basic requirements	Class III	N/A
	Instructions when protection relies on building installation		N/A
2.7.2	Faults not simulated in 5.3.7	Class III	N/A
2.7.3	Short-circuit backup protection	Class III	N/A
2.7.4	Number and location of protective devices	Class III	N/A
2.7.5	Protection by several devices	Class III	N/A
2.7.6	Warning to service personnel	Class III	N/A

2.8	Safety interlocks		N/A
2.8.1	General principles	No interlock is provided	N/A
2.8.2	Protection requirements		N/A
2.8.3	Inadvertent reactivation		N/A
2.8.4	Fail-safe operation		N/A
	Protection against extreme hazard		N/A
2.8.5	Moving parts		N/A
2.8.6	Overriding		N/A
2.8.7	Switches, relays and their related circuits		N/A
2.8.7.1	Separation distances for contact gaps and their related circuits (mm)		N/A
2.8.7.2	Overload test		N/A
2.8.7.3	Endurance test		N/A
2.8.7.4	Electric strength test	(see appended table 5.2)	N/A
2.8.8	Mechanical actuators		N/A

2.9	Electrical insulation		P
2.9.1	Properties of insulating materials	Class III Functional insulation only	N/A
2.9.2	Humidity conditioning		N/A
	Relative humidity (%), temperature (°C)		—
2.9.3	Grade of insulation	Functional insulation employed in secondary SELV evaluated to 5.3.4 c)	P
2.9.4	Separation from hazardous voltages	Class III	P
	Method(s) used	Reinforced	—

2.10	Clearances, creepage distances and distances through insulation		P
2.10.1	General	Class III , Creepage distances, clearances and DTI are not relied upon for safety. Considerations for functional insulation were considered through 5.3.4.c	N/A
2.10.1.1	Frequency		N/A
2.10.1.2	Pollution degrees		N/A
2.10.1.3	Reduced values for functional insulation		N/A
2.10.1.4	Intervening unconnected conductive parts		N/A
2.10.1.5	Insulation with varying dimensions		N/A
2.10.1.6	Special separation requirements		N/A
2.10.1.7	Insulation in circuits generating starting pulses		N/A
2.10.2	Determination of working voltage	Class III , Creepage distances, clearances and DTI are not relied upon for safety. Considerations for functional insulation were considered through 5.3.4.c	N/A
2.10.2.1	General		N/A
2.10.2.2	RMS working voltage		N/A
2.10.2.3	Peak working voltage		N/A
2.10.3	Clearances	Class III , Creepage distances, clearances and DTI are not relied upon for safety. Considerations for functional insulation were considered through 5.3.4.c	N/A
2.10.3.1	General		N/A
2.10.3.2	Mains transient voltages		N/A
	a) AC mains supply		N/A
	b) Earthed d.c. mains supplies		N/A
	c) Unearthed d.c. mains supplies		N/A
	d) Battery operation		N/A
2.10.3.3	Clearances in primary circuits		N/A
2.10.3.4	Clearances in secondary circuits		N/A
2.10.3.5	Clearances in circuits having starting pulses		N/A
2.10.3.6	Transients from a.c. mains supply		N/A
2.10.3.7	Transients from d.c. mains supply		N/A
2.10.3.8	Transients from telecommunication networks and cable distribution systems		N/A



2.10.3.9	Measurement of transient voltage levels		N/A
	a) Transients from a mains supply		N/A
	For an a.c. mains supply		N/A
	For a d.c. mains supply		
	b) Transients from a telecommunication network :		
2.10.4	Creepage distances	Class III , Creepage distances, clearances and DTI are not relied upon for safety. Considerations for functional insulation were considered through 5.3.4.c	N/A
2.10.4.1	General		N/A
2.10.4.2	Material group and comparative tracking index		
	CTI tests	Material group IIIb is assumed to be used	—
2.10.4.3	Minimum creepage distances	(see appended table 2.10.3 and 2.10.4)	N/A
2.10.5	Solid insulation		
2.10.5.1	General	Class III	N/A
2.10.5.2	Distances through insulation	(see appended table 2.10.5)	N/A
2.10.5.3	Insulating compound as solid insulation		N/A
2.10.5.4	Semiconductor devices		N/A
2.10.5.5.	Cemented joints	(see appended table 2.10.3 and 2.10.4)	N/A
2.10.5.6	Thin sheet material – General		N/A
2.10.5.7	Separable thin sheet material		N/A
	Number of layers (pcs)		—
2.10.5.8	Non-separable thin sheet material		N/A
2.10.5.9	Thin sheet material – standard test procedure		N/A
	Electric strength test	(see appended table 2.10.5)	—
2.10.5.10	Thin sheet material – alternative test procedure		N/A
	Electric strength test	(see appended table 2.10.5)	—
2.10.5.11	Insulation in wound components		N/A
2.10.5.12	Wire in wound components		N/A
	Working voltage		N/A
	a) Basic insulation not under stress		N/A
	b) Basic, supplementary, reinforced insulation		N/A
	c) Compliance with Annex U		N/A
	Two wires in contact inside wound component; angle between 45° and 90°		N/A

2.10.5.13	Wire with solvent-based enamel in wound components		N/A
	Electric strength test	(see appended table 2.10.5)	—
	Routine test		N/A
2.10.5.14	Additional insulation in wound components		N/A
	Working voltage		N/A
	- Basic insulation not under stress		N/A
	- Supplementary, reinforced insulation		N/A
2.10.6	Construction of printed boards	Class III	N/A
2.10.6.1	Uncoated printed boards	(see appended table 2.10.3 and 2.10.4)	N/A
2.10.6.2	Coated printed boards	(see appended table 2.10.3 and 2.10.4)	N/A
2.10.6.3	Insulation between conductors on the same inner surface of a printed board	(see appended table 2.10.3 and 2.10.4)	N/A
2.10.6.4	Insulation between conductors on different layers of a printed board		N/A
	Distance through insulation	(see appended table 2.10.5)	N/A
	Number of insulation layers (pcs).....		N/A
2.10.7	Component external terminations	(see appended table 2.10.3 and 2.10.4)	N/A
2.10.8	Tests on coated printed boards and coated components	No such components	N/A
2.10.8.1	Sample preparation and preliminary inspection		N/A
2.10.8.2	Thermal conditioning		N/A
2.10.8.3	Electric strength test	(see appended table 5.2)	N/A
2.10.8.4	Abrasion resistance test		N/A
2.10.9	Thermal cycling		N/A
2.10.10	Test for Pollution Degree 1 environment and insulating compound		N/A
2.10.11	Tests for semiconductor devices and cemented joints		N/A
2.10.12	Enclosed and sealed parts		N/A

3	WIRING, CONNECTIONS AND SUPPLY		P
3.1	General		P
3.1.1	Current rating and overcurrent protection	Wiring gauge is suitable for rated current	P
3.1.2	Protection against mechanical damage	Internal wiring is protected against mechanical damage	P

3.1.3	Securing of internal wiring	Class III	N/A
3.1.4	Insulation of conductors	Class III	N/A
3.1.5	Beads and ceramic insulators	No such components	N/A
3.1.6	Screws for electrical contact pressure	Screws are not used for electrical contact pressure	N/A
3.1.7	Insulating materials in electrical connections	No such materials.	N/A
3.1.8	Self-tapping and spaced thread screws	No such screws	N/A
3.1.9	Termination of conductors		N/A
	10 N pull test		N/A
3.1.10	Sleeving on wiring		N/A

3.2	Connection to a mains supply		N/A
3.2.1	Means of connection	Class III- no connection to mains supply	N/A
3.2.1.1	Connection to an a.c. mains supply		N/A
3.2.1.2	Connection to a d.c. mains supply		N/A
3.2.2	Multiple supply connections		N/A
3.2.3	Permanently connected equipment		N/A
	Number of conductors, diameter of cable and conduits (mm)		—
3.2.4	Appliance inlets		N/A
3.2.5	Power supply cords		N/A
3.2.5.1	AC power supply cords		N/A
	Type		—
	Rated current (A), cross-sectional area (mm ²), AWG		—
3.2.5.2	DC power supply cords	Class III	N/A
3.2.6	Cord anchorages and strain relief		N/A
	Mass of equipment (kg), pull (N)		—
	Longitudinal displacement (mm)		—
3.2.7	Protection against mechanical damage		N/A
3.2.8	Cord guards		N/A
	Diameter or minor dimension D (mm); test mass (g)		—
	Radius of curvature of cord (mm)		—
3.2.9	Supply wiring space		N/A

3.3	Wiring terminals for connection of external conductors		N/A
------------	---	--	-----

3.3.1	Wiring terminals	Class III, terminal is provided with two screws	N/A
3.3.2	Connection of non-detachable power supply cords		N/A
3.3.3	Screw terminals		N/A
3.3.4	Conductor sizes to be connected		N/A
	Rated current (A), cord/cable type, cross-sectional area (mm ²)		—
3.3.5	Wiring terminal sizes		N/A
	Rated current (A), type, nominal thread diameter (mm)		—
3.3.6	Wiring terminal design		N/A
3.3.7	Grouping of wiring terminals		N/A
3.3.8	Stranded wire		N/A

3.4	Disconnection from the mains supply		N/A
3.4.1	General requirement	Class III- No connection to mains Connection to DC power is made by terminal screwed by two screws	N/A
3.4.2	Disconnect devices		N/A
3.4.3	Permanently connected equipment		N/A
3.4.4	Parts which remain energized		N/A
3.4.5	Switches in flexible cords		N/A
3.4.6	Number of poles - single-phase and d.c. equipment		N/A
3.4.7	Number of poles - three-phase equipment		N/A
3.4.8	Switches as disconnect devices		N/A
3.4.9	Plugs as disconnect devices		N/A
3.4.10	Interconnected equipment		N/A
3.4.11	Multiple power sources		N/A

3.5	Interconnection of equipment		P
3.5.1	General requirements		P
3.5.2	Types of interconnection circuits	SELV circuits to SELV circuits	P
3.5.3	ELV circuits as interconnection circuits	No Such circuits	N/A
3.5.4	Data ports for additional equipment	Data ports for connection to additional equipment comply with LPS requirements of 2.5 (inherently limited signal/data ports) The whole system is LPS powered	P

4	PHYSICAL REQUIREMENTS		P
4.1	Stability		P
	Angle of 10°	Fixed installation Class III, units are less than 7Kg	N/A
	Test force (N)		N/A

4.2	Mechanical strength		P
4.2.1	General	Class III, units contain LPS circuits ,enclosed with plastic enclosure	P
	Rack-mounted equipment.	(see Annex DD)	N/A
4.2.2	Steady force test, 10 N	No parts requiring this test	N/A
4.2.3	Steady force test, 30 N	No covers or doors in operator access area	N/A
4.2.4	Steady force test, 250 N	Class III	N/A
4.2.5	Impact test		N/A
	Fall test		N/A
	Swing test		N/A
4.2.6	Drop test; height (mm)		N/A
4.2.7	Stress relief test		N/A
4.2.8	Cathode ray tubes		N/A
	Picture tube separately certified	(see separate test report or attached certificate)	N/A
4.2.9	High pressure lamps		N/A
4.2.10	Wall or ceiling mounted equipment; force (N)		N/A

4.3	Design and construction		P
4.3.1	Edges and corners	All edges and corners are well rounded and smoothed so as not to constitute a hazard	P
4.3.2	Handles and manual controls; force (N)	No such parts	N/A
4.3.3	Adjustable controls	No adjustable controls	N/A
4.3.4	Securing of parts	Class III LPS powered unit	N/A
4.3.5	Connection by plugs and sockets	No possibility of misconnection	N/A
4.3.6	Direct plug-in equipment	Class III Not direct plug-in equipment	N/A
	Torque		—

	Compliance with the relevant mains plug standard		N/A
4.3.7	Heating elements in earthed equipment		N/A
4.3.8	Batteries	Rechargeable Lithium battery pack is compatible with output of charger circuit. Reverse polarity installation is eliminated	P
	- Overcharging of a rechargeable battery	Battery pack was fully charged and then it was overcharged during 7 h, see table 5.3	P
	- Unintentional charging of a non-rechargeable battery	Rechargeable battery used	N/A
	- Reverse charging of a rechargeable battery	There is no possibility of reverse charging	N/A
	- Excessive discharging rate for any battery	Refer to Table 4.3.8, 5.3	P
4.3.9	Oil and grease	No oil and grease	N/A
4.3.10	Dust, powders, liquids and gases	Refer to test report 20091109-1038 – Original IP67 test report done by Qualitech	P
4.3.11	Containers for liquids or gases	No such components	N/A
4.3.12	Flammable liquids	No such components	N/A
	Quantity of liquid (l)		N/A
	Flash point (°C)		N/A
4.3.13	Radiation	No such components	N/A
4.3.13.1	General		N/A
4.3.13.2	Ionizing radiation		N/A
	Measured radiation (pA/kg)		—
	Measured high-voltage (kV)		—
	Measured focus voltage (kV)		—
	CRT markings		—
4.3.13.3	Effect of ultraviolet (UV) radiation on materials		N/A
	Part, property, retention after test, flammability classification		N/A
4.3.13.4	Human exposure to ultraviolet (UV) radiation	No such components	N/A
4.3.13.5	Lasers (including laser diodes) and LEDs	No such components	N/A
4.3.13.5.1	Lasers (including laser diodes)		N/A
	Laser class		—
4.3.13.5.2	Light emitting diodes (LEDs)		—
4.3.13.6	Other types		N/A

4.4	Protection against hazardous moving parts		N/A
4.4.1	General	No moving parts	N/A
4.4.2	Protection in operator access areas		N/A
	Household and home/office document/media shredders	(see Annex EE)	N/A
4.4.3	Protection in restricted access locations		N/A
4.4.4	Protection in service access areas		N/A
4.4.5	Protection against moving fan blades		N/A
4.4.5.1	General		N/A
	Not considered to cause pain or injury. a).....:		N/A
	Is considered to cause pain, not injury. b)		N/A
	Considered to cause injury. c)		N/A
4.4.5.2	Protection for users		N/A
	Use of symbol or warning		N/A
4.4.5.3	Protection for service persons		N/A
	Use of symbol or warning		N/A

4.5	Thermal requirements		P
4.5.1	General	Temperatures do not exceed safe values under normal load operation. Refer to Table 4.5.	P
4.5.2	Temperature tests	Refer to Table 4.5	P
	Normal load condition per Annex L	Unit operated per its maximum normal load configuration.	—
4.5.3	Temperature limits for materials	(see appended table 4.5)	P
4.5.4	Touch temperature limits	(see appended table 4.5)	P
4.5.5	Resistance to abnormal heat	(see appended table 4.5.5)	N/A

4.6	Openings in enclosures		N/A
4.6.1	Top and side openings	No openings	N/A
	Dimensions (mm)		—
4.6.2	Bottoms of fire enclosures	Class II, units with LPS No openings	N/A
	Construction of the bottom, dimensions (mm) ..:		—
4.6.3	Doors or covers in fire enclosures		N/A
4.6.4	Openings in transportable equipment		N/A
4.6.4.1	Constructional design measures		N/A

	Dimensions (mm)		—
4.6.4.2	Evaluation measures for larger openings		N/A
4.6.4.3	Use of metallized parts		N/A
4.6.5	Adhesives for constructional purposes		N/A
	Conditioning temperature (°C), time (weeks).....		—

4.7	Resistance to fire		P
4.7.1	Reducing the risk of ignition and spread of flame		P
	Method 1, selection and application of components wiring and materials	Method 1: Selection and application of components and materials, which minimize the possibility of ignition and spread of flame.	P
	Method 2, application of all of simulated fault condition tests	Method 1 used	N/A
4.7.2	Conditions for a fire enclosure	Fire enclosure not required: unit is LPS powered, PCB is flame rated V-0, plastic enclosure is rated V-0	P
4.7.2.1	Parts requiring a fire enclosure	No such parts	N/A
4.7.2.2	Parts not requiring a fire enclosure	Not required fire enclosure	N/A
4.7.3	Materials		P
4.7.3.1	General	Enclosure and other components so constructed and such materials used, that the propagation of fire is limited.	P
4.7.3.2	Materials for fire enclosures	Fire enclosure not required: unit is LPS powered, PCB is flame rated V-0, plastic enclosure is rated 5VB	P
4.7.3.3	Materials for components and other parts outside fire enclosures		N/A
4.7.3.4	Materials for components and other parts inside fire enclosures	Not required fire enclosure	N/A
4.7.3.5	Materials for air filter assemblies		N/A
4.7.3.6	Materials used in high-voltage components		N/A

5	ELECTRICAL REQUIREMENTS AND SIMULATED ABNORMAL CONDITIONS		N/A
5.1	Touch current and protective conductor current		N/A
5.1.1	General	DC unit	N/A
5.1.2	Configuration of equipment under test (EUT)		N/A
5.1.2.1	Single connection to an a.c. mains supply		N/A
5.1.2.2	Redundant multiple connections to an a.c. mains supply		N/A
5.1.2.3	Simultaneous multiple connections to an a.c. mains supply		N/A
5.1.3	Test circuit		N/A
5.1.4	Application of measuring instrument		N/A
5.1.5	Test procedure		N/A
5.1.6	Test measurements		N/A
	Supply voltage (V)		—
	Measured touch current (mA)		—
	Max. allowed touch current (mA)		—
	Measured protective conductor current (mA)		—
	Max. allowed protective conductor current (mA) ...		—
5.1.7	Equipment with touch current exceeding 3,5 mA		N/A
5.1.7.1	General		N/A
5.1.7.2	Simultaneous multiple connections to the supply		N/A
5.1.8	Touch currents to telecommunication networks and cable distribution systems and from telecommunication networks		N/A
5.1.8.1	Limitation of the touch current to a telecommunication network or to a cable distribution system		N/A
	Supply voltage (V)		—
	Measured touch current (mA)		—
	Max. allowed touch current (mA)		—
5.1.8.2	Summation of touch currents from telecommunication networks		N/A
	a) EUT with earthed telecommunication ports		N/A
	b) EUT whose telecommunication ports have no reference to protective earth		N/A
5.2	Electric strength		N/A
5.2.1	General	Class III	N/A
5.2.2	Test procedure		N/A

5.3	Abnormal operating and fault conditions		P
5.3.1	Protection against overload and abnormal operation	Were considered - (see appended table 5.3)	P
5.3.2	Motors	(see appended Annex B)	N/A
5.3.3	Transformers	Class III (see appended Annex C)	N/A
5.3.4	Functional insulation..... :	Evaluated and considered through 5.3.4 c). All components in SELV are mounted on PCB having flammability rating UL94V-0, unit is LPS	P
5.3.5	Electromechanical components		N/A
5.3.6	Audio amplifiers in ITE :		N/A
5.3.7	Simulation of faults	No electromechanical components	N/A
5.3.8	Unattended equipment	No such parts	N/A
5.3.9	Compliance criteria for abnormal operating and fault conditions	No fire, chemical leaks or explosion. No hazard	P
5.3.9.1	During the tests	No fire, chemical leaks or explosion. No hazard	P
5.3.9.2	After the tests	No fire, chemical leaks or explosion. No hazard	P

6	CONNECTION TO TELECOMMUNICATION NETWORKS		N/A
6.1	Protection of telecommunication network service persons, and users of other equipment connected to the network, from hazards in the equipment		
6.1.1	Protection from hazardous voltages		N/A
6.1.2	Separation of the telecommunication network from earth		N/A
6.1.2.1	Requirements	No TNV circuits or connection to telecommunication network	N/A
	Supply voltage (V)		—
	Current in the test circuit (mA)		—
6.1.2.2	Exclusions		N/A

6.2	Protection of equipment users from overvoltages on telecommunication networks		N/A
6.2.1	Separation requirements		N/A
6.2.2	Electric strength test procedure		N/A
6.2.2.1	Impulse test	(see appended table 5.2)	N/A
6.2.2.2	Steady-state test	(see appended table 5.2)	N/A
6.2.2.3	Compliance criteria		N/A

6.3	Protection of the telecommunication wiring system from overheating		N/A
	Max. output current (A)		—
	Current limiting method		—

7	CONNECTION TO CABLE DISTRIBUTION SYSTEMS		N/A
7.1	General	No connection to cable distribution system	N/A
7.2	Protection of cable distribution system service persons, and users of other equipment connected to the system, from hazardous voltages in the equipment		N/A
7.3	Protection of equipment users from overvoltages on the cable distribution system		N/A
7.4	Insulation between primary circuits and cable distribution systems		N/A
7.4.1	General		N/A
7.4.2	Voltage surge test	(see appended table 5.2)	N/A
7.4.3	Impulse test	(see appended table 5.2)	N/A

A	ANNEX A, TESTS FOR RESISTANCE TO HEAT AND FIRE		N/A
A.1	Flammability test for fire enclosures of movable equipment having a total mass exceeding 18 kg, and of stationary equipment (see 4.7.3.2)		N/A
A.1.1	Samples		—
	Wall thickness (mm)		—
A.1.2	Conditioning of samples; temperature (°C)		N/A
A.1.3	Mounting of samples		N/A
A.1.4	Test flame (see IEC 60695-11-3)		N/A
	Flame A, B, C or D		—
A.1.5	Test procedure		N/A
A.1.6	Compliance criteria		N/A
	Sample 1 burning time (s)		—
	Sample 2 burning time (s)		—
	Sample 3 burning time (s)		—
A.2	Flammability test for fire enclosures of movable equipment having a total mass not exceeding 18 kg, and for material and components located inside fire enclosures (see 4.7.3.2 and 4.7.3.4)		N/A
A.2.1	Samples, material		—
	Wall thickness (mm)		—
A.2.2	Conditioning of samples; temperature (°C)		N/A
A.2.3	Mounting of samples		N/A
A.2.4	Test flame (see IEC 60695-11-4)		N/A
	Flame A, B or C		—

A.2.5	Test procedure		N/A
A.2.6	Compliance criteria		N/A
	Sample 1 burning time (s)..... :		—
	Sample 2 burning time (s)..... :		—
	Sample 3 burning time (s)..... :		—
A.2.7	Alternative test acc. to IEC 60695-11-5, cl. 5 and 9		N/A
	Sample 1 burning time (s)..... :		—
	Sample 2 burning time (s)..... :		—
	Sample 3 burning time (s)..... :		—
A.3	Hot flaming oil test (see 4.6.2)		N/A
A.3.1	Mounting of samples		N/A
A.3.2	Test procedure		N/A
A.3.3	Compliance criterion		N/A

B	ANNEX B, MOTOR TESTS UNDER ABNORMAL CONDITIONS (see 4.7.2.2 and 5.3.2)		N/A
B.1	General requirements	No motors or DC fans	N/A
	Position		—
	Manufacturer		—
	Type		—
	Rated values		—
B.2	Test conditions		N/A
B.3	Maximum temperatures	(see appended table 5.3)	N/A
B.4	Running overload test	(see appended table 5.3)	N/A
B.5	Locked-rotor overload test		N/A
	Test duration (days)		—
	Electric strength test: test voltage (V)		—
B.6	Running overload test for d.c. motors in secondary circuits		N/A
B.6.1	General		N/A
B.6.2	Test procedure		N/A
B.6.3	Alternative test procedure		N/A
B.6.4	Electric strength test; test voltage (V)		N/A
B.7	Locked-rotor overload test for d.c. motors in secondary circuits		N/A
B.7.1	General		N/A
B.7.2	Test procedure		N/A
B.7.3	Alternative test procedure		N/A



B.7.4	Electric strength test; test voltage (V)		N/A
B.8	Test for motors with capacitors	(see appended table 5.3)	N/A
B.9	Test for three-phase motors	(see appended table 5.3)	N/A
B.10	Test for series motors		N/A
	Operating voltage (V)		—

C	ANNEX C, TRANSFORMERS (see 1.5.4 and 5.3.3)		N/A
	Position	Class III	—
	Manufacturer		—
	Type		—
	Rated values		—
	Method of protection		—
C.1	Overload test	(see appended table 5.3)	N/A
C.2	Insulation	(see appended tables 5.2 and C2)	N/A
	Protection from displacement of windings		N/A

D	ANNEX D, MEASURING INSTRUMENTS FOR TOUCH-CURRENT TESTS (see 5.1.4)		N/A
D.1	Measuring instrument		N/A
D.2	Alternative measuring instrument		N/A

E	ANNEX E, TEMPERATURE RISE OF A WINDING (see 1.4.13)		N/A
----------	--	--	-----



F	ANNEX F, MEASUREMENT OF CLEARANCES AND CREEPAGE DISTANCES (see 2.10 and Annex G)	N/A
----------	---	-----

G	ANNEX G, ALTERNATIVE METHOD FOR DETERMINING MINIMUM CLEARANCES	N/A	
G.1	Clearances	Not required	N/A
G.1.1	General		N/A
G.1.2	Summary of the procedure for determining minimum clearances		N/A
G.2	Determination of mains transient voltage (V)		N/A
G.2.1	AC mains supply		N/A
G.2.2	Earthed d.c. mains supplies		N/A
G.2.3	Unearthed d.c. mains supplies		N/A
G.2.4	Battery operation		N/A
G.3	Determination of telecommunication network transient voltage (V)		N/A
G.4	Determination of required withstand voltage (V)		N/A
G.4.1	Mains transients and internal repetitive peaks		N/A
G.4.2	Transients from telecommunication networks		N/A
G.4.3	Combination of transients		N/A
G.4.4	Transients from cable distribution systems		N/A
G.5	Measurement of transient voltages (V)		N/A
	a) Transients from a mains supply		N/A
	For an a.c. mains supply		N/A
	For a d.c. mains supply		N/A
	b) Transients from a telecommunication network		N/A
G.6	Determination of minimum clearances		N/A

H	ANNEX H, IONIZING RADIATION (see 4.3.13)	N/A
----------	---	-----

J	ANNEX J, TABLE OF ELECTROCHEMICAL POTENTIALS (see 2.6.5.6)	N/A
	Metal(s) used	—

K	ANNEX K, THERMAL CONTROLS (see 1.5.3 and 5.3.8)	N/A	
K.1	Making and breaking capacity		N/A
K.2	Thermostat reliability; operating voltage (V)		N/A
K.3	Thermostat endurance test; operating voltage (V)		N/A

K.4	Temperature limiter endurance; operating voltage (V)		N/A
K.5	Thermal cut-out reliability		N/A
K.6	Stability of operation	(see appended table 5.3)	N/A

L	ANNEX L, NORMAL LOAD CONDITIONS FOR SOME TYPES OF ELECTRICAL BUSINESS EQUIPMENT (see 1.2.2.1 and 4.5.2)		P
L.1	Typewriters		N/A
L.2	Adding machines and cash registers		N/A
L.3	Erasers		N/A
L.4	Pencil sharpeners		N/A
L.5	Duplicators and copy machines		N/A
L.6	Motor-operated files		N/A
L.7	Other business equipment		P

M	ANNEX M, CRITERIA FOR TELEPHONE RINGING SIGNALS (see 2.3.1)		N/A
M.1	Introduction	No telephone ringing signals	N/A
M.2	Method A		N/A
M.3	Method B		N/A
M.3.1	Ringing signal		N/A
M.3.1.1	Frequency (Hz)		—
M.3.1.2	Voltage (V)		—
M.3.1.3	Cadence; time (s), voltage (V)		—
M.3.1.4	Single fault current (mA)		—
M.3.2	Tripping device and monitoring voltage		N/A
M.3.2.1	Conditions for use of a tripping device or a monitoring voltage		N/A
M.3.2.2	Tripping device		N/A
M.3.2.3	Monitoring voltage (V)		N/A

N	ANNEX N, IMPULSE TEST GENERATORS (see 1.5.7.2, 1.5.7.3, 2.10.3.9, 6.2.2.1, 7.3.2, 7.4.3 and Clause G.5)		N/A
N.1	ITU-T impulse test generators		N/A
N.2	IEC 60065 impulse test generator		N/A
P	ANNEX P, NORMATIVE REFERENCES		—
Q	ANNEX Q, Voltage dependent resistors (VDRs) (see 1.5.9.1)		N/A
	a) Preferred climatic categories	CLASS III	N/A
	b) Maximum continuous voltage		N/A
	c) Pulse current		N/A
R	ANNEX R, EXAMPLES OF REQUIREMENTS FOR QUALITY CONTROL PROGRAMMES		N/A
R.1	Minimum separation distances for unpopulated coated printed boards (see 2.10.6.2)		N/A
R.2	Reduced clearances (see 2.10.3)		N/A
S	ANNEX S, PROCEDURE FOR IMPULSE TESTING (see 6.2.2.3)		N/A
S.1	Test equipment		N/A
S.2	Test procedure		N/A
S.3	Examples of waveforms during impulse testing		N/A
T	ANNEX T, GUIDANCE ON PROTECTION AGAINST INGRESS OF WATER (see 1.1.2)		N/A
		IPX0	—
U	ANNEX U, INSULATED WINDING WIRES FOR USE WITHOUT INTERLEAVED INSULATION (see 2.10.5.4)		N/A
		See separate test report	—
V	ANNEX V, AC POWER DISTRIBUTION SYSTEMS (see 1.6.1)		N/A
V.1	Introduction		N/A
V.2	TN power distribution systems		N/A
W	ANNEX W, SUMMATION OF TOUCH CURRENTS		N/A
W.1	Touch current from electronic circuits	Class III	N/A

W.1.1	Floating circuits		N/A
W.1.2	Earthed circuits		N/A
W.2	Interconnection of several equipments		N/A
W.2.1	Isolation		N/A
W.2.2	Common return, isolated from earth		N/A
W.2.3	Common return, connected to protective earth		N/A

X	ANNEX X, MAXIMUM HEATING EFFECT IN TRANSFORMER TESTS (see clause C.1)		N/A
X.1	Determination of maximum input current		N/A
X.2	Overload test procedure		N/A

Y	ANNEX Y, ULTRAVIOLET LIGHT CONDITIONING TEST (see 4.3.13.3)		N/A
Y.1	Test apparatus	The unit does not expose to UV	N/A
Y.2	Mounting of test samples		N/A
Y.3	Carbon-arc light-exposure apparatus		N/A
Y.4	Xenon-arc light exposure apparatus		N/A

Z	ANNEX Z, OVERVOLTAGE CATEGORIES (see 2.10.3.2 and Clause G.2)		N/A
----------	--	--	-----

AA	ANNEX AA, MANDREL TEST (see 2.10.5.8)		N/A
-----------	--	--	-----

BB	ANNEX BB, CHANGES IN THE SECOND EDITION		—
-----------	--	--	---

CC	ANNEX CC, Evaluation of integrated circuit (IC) current limiters		N/A
CC.1	General		N/A
CC.2	Test program 1.....		N/A
CC.3	Test program 2.....		N/A

DD	ANNEX DD, Requirements for the mounting means of rack-mounted equipment		N/A
DD.1	General		N/A
DD.2	Mechanical strength test, variable N.....		N/A
DD.3	Mechanical strength test, 250N, including end stops.....		N/A
DD.4	Compliance.....		N/A

EE	ANNEX EE, Household and home/office document/media shredders		N/A
EE.1	General		N/A



EE.2	Markings and instructions		N/A
	Use of markings or symbols.....:		N/A
	Information of user instructions, maintenance and/or servicing instructions.....:		N/A
EE.3	Inadvertent reactivation test.....:		N/A
EE.4	Disconnection of power to hazardous moving parts:		N/A
	Use of markings or symbols.....:		N/A
EE.5	Protection against hazardous moving parts		N/A
	Test with test finger (Figure 2A)		N/A
	Test with wedge probe (Figure EE1 and EE2)		N/A

1.5.1	TABLE: List of critical components				
Object/part No.	Manufacturer/ trademark	Type/model	Technical data	Standard (Edition / year)	Mark(s) of conformity ¹⁾
Plastic enclosure	Any	Any	Flame rated: UL94 V-0	UL94	UL Recognized
PCB	Any	Any	Flame rated: UL94 V-1 minimum	UL796	UL Recognized
Lithium battery	Advanced Electronics Energy Ltd.	AE9551119P	Rated: 3.7V, 13.6Ah; maximum charging current 6500mA, maximum charging voltage 4.5V	UL1642	UL Recognized
* Alternate PTC F2for power circuit	Bourns	MF-R090	Rated – 60V Max. I max-40A I hold-0.9A Itrip- 1.8A	UL1434 IEC60730-1	UL Recognized TUV
Fuses PTC (battery load circuit and input power from charger)	Thinking Electronic Industrial Co., Ltd. or equivalent	KRG0300160IR Y or equivalent	Rated: 30V, I hold 1.6A, I trip 3.2A	UL1434 IEC60730-1	UL Recognized TUV
Fuse PTC F2 (input power from dc mains)	BOURNS or equivalent	MF-RX110/72 or equivalent	Rated: 72V, I hold 1.1A, I trip 2.2A	UL1434 IEC60730-1	UL Recognized TUV
Fuses PTC (battery load circuit and input power from charger)	BOURNS or equivalent	MF-R160 or equivalent	Rated: 30V, I hold 1.6A, I trip 3.2A	UL1434 IEC60730-1	UL Recognized TUV

Lithium battery pack: includes	GP Batteries	NTRLO1801004	Rated: 3.7V, 4.25Ah; maximum charging current 3A, maximum charging voltage 4.2V Maximum discharge current 3A Protection circuit incorporates 2 FETs in series	UL1642	Evaluated
Lithium battery	Yoko Energy Co	064080	Rated: 3.7V, 2Ah; maximum charging current 650mA, maximum charging voltage 4.2V Maximum discharge current 1A PCM: YK-ML74E, incorporates 2 FETs in series	UL1642	UL Recognized
*Alternate Lithium battery	Yoko Energy Co	9551119	Rated: 3.7V, 13Ah; maximum charging current 400mA, maximum charging voltage 4.8V Maximum discharge current 2A PCM: YK-ML74I, incorporates 2 FETs in series	UL1642	UL Recognized



Lithium battery cell (part of battery pack above)	Boston Power	Sonata 4400	Maximum charging current 8.8A Maximum charging Voltage 4.5V	UL1642	UL Recognized
Step-down converter (option 1)	Texas Instrument	TPS-5430	Rated: input 5.5-36V Output: 3A, adjustable voltage		Note*
Supplementary information: ¹⁾					

1.5.1	TABLE: Opto Electronic Devices	N/A
Manufacturer : Type..... : Separately tested..... : Bridging insulation : External creepage distance : Internal creepage distance : Distance through insulation : Tested under the following conditions : Input..... : Output..... : supplementary information		

1.6.2	TABLE: Electrical data (in normal conditions)	N/A				
U (V)	I (A)	Irated (A)	P (W)	Fuse #	Ifuse (A)	Condition/status
9	0.51	0.6	-	-	-	Maximum normal load (with Thinking Electronic Industrial Co., Ltd. battery)
32	0.15	0.6	-	-	-	Maximum normal load (with Thinking Electronic Industrial Co., Ltd. battery)
9	0.54	0.6	-	-	-	Maximum normal load (with GP battery)
32	0.17	0.6	-	-	-	Maximum normal load (with GP battery)
9	0.54	0.6	-	-	-	Maximum normal load (with Yoku battery)
32	0.17	0.6	-	-	-	Maximum normal load (with Yoku battery)
Supplementary information: Class III ,Informative measurments information . Tests were performed when the battery was empty.						

2.1.1.5 c) 1)	TABLE: max. V, A, VA test	N/A
----------------------	----------------------------------	-----

Voltage (rated) (V)	Current (rated) (A)	Voltage (max.) (V)	Current (max.) (A)	VA (max.) (VA)
supplementary information:				

2.1.1.5 c) 2)	TABLE: stored energy	N/A
Capacitance C (μ F)	Voltage U (V)	Energy E (J)
supplementary information:		

2.2	TABLE: evaluation of voltage limiting components in SELV circuits	N/A	
Component (measured between)	max. voltage (V) (normal operation)		Voltage Limiting Components
	V peak	V d.c.	
Fault test performed on voltage limiting components	Voltage measured (V) in SELV circuits (V peak or V d.c.)		
supplementary information:			

2.5	TABLE: Limited power sources					N/A
Circuit output tested:						
Note: Measured Uoc (V) with all load circuits disconnected:						
Components	Sample No.	Uoc (V)	I _{sc} (A)		VA	
			Meas.	Limit	Meas.	Limit
supplementary information:						
Sc=Short circuit, Oc=Open circuit						

2.10.2	Table: working voltage measurement			N/A
Location	RMS voltage (V)	Peak voltage (V)	Comments	
supplementary information:				

2.10.3 and 2.10.4	TABLE: Clearance and creepage distance measurements						N/A
Clearance (cl) and creepage distance (cr) at/of/between:	U peak (V)	U r.m.s. (V)	Required cl (mm)	cl (mm)	Required cr (mm)	cr (mm)	
Functional:							
Basic/supplementary:							
Reinforced:							
Supplementary information:Class III							

2.10.5	TABLE: Distance through insulation measurements					N/A
Distance through insulation (DTI) at/of:	U peak (V)	U rms (V)	Test voltage (V)	Required DTI (mm)	DTI (mm)	
Supplementary information:						

4.3.8	TABLE: Batteries									P
The tests of 4.3.8 are applicable only when appropriate battery data is not available							Battery pack was tested for single faults in charging and discharging circuit, see results below			P
Is it possible to install the battery in a reverse polarity position?							No			P
	Non-rechargeable batteries			Rechargeable batteries						
	Discharging		Un-intentional charging	Charging		Discharging		Reversed charging		
	Meas. current	Manuf. Specs.		Meas. current	Manuf. Specs.	Meas. current	Manuf. Specs.	Meas. current	Manuf. Specs.	
With GP Battery										
Max. current during normal condition	--	--	--	0.8A	8.8A	0.18A	3A	--	--	
Max. current during fault condition	--	--	--	Same as in normal condition	-	Max. 3.2A according to rating of PTC at battery pack output	Same as in normal condition	--	--	
With Yoku battery										
Max. current during normal condition	--	--	--	0.45A	4A	0.18A	2A	--	--	
Max. current during fault condition	--	--	--	Same as in normal condition	-	Max. 3.2A according to rating of PTC at battery pack output	Same as in normal condition	--	--	

Test results:		Verdict
- Chemical leaks	No	P
- Explosion of the battery	No	P
- Emission of flame or expulsion of molten metal	No	P
- Electric strength tests of equipment after completion of tests	Not required	N/A

Supplementary information:	
4.3.8	TABLE: Batteries
	P

Battery category..... : (Lithium, NiMH, NiCad, Lithium Ion ...)
 Manufacturer : See appended table 1.5.1
 Type / model..... : See appended table 1.5.1
 Voltage : See appended table 1.5.1
 Capacity..... : mAh
 Tested and Certified by (incl. Ref. No.) : See below
 Circuit protection diagram:

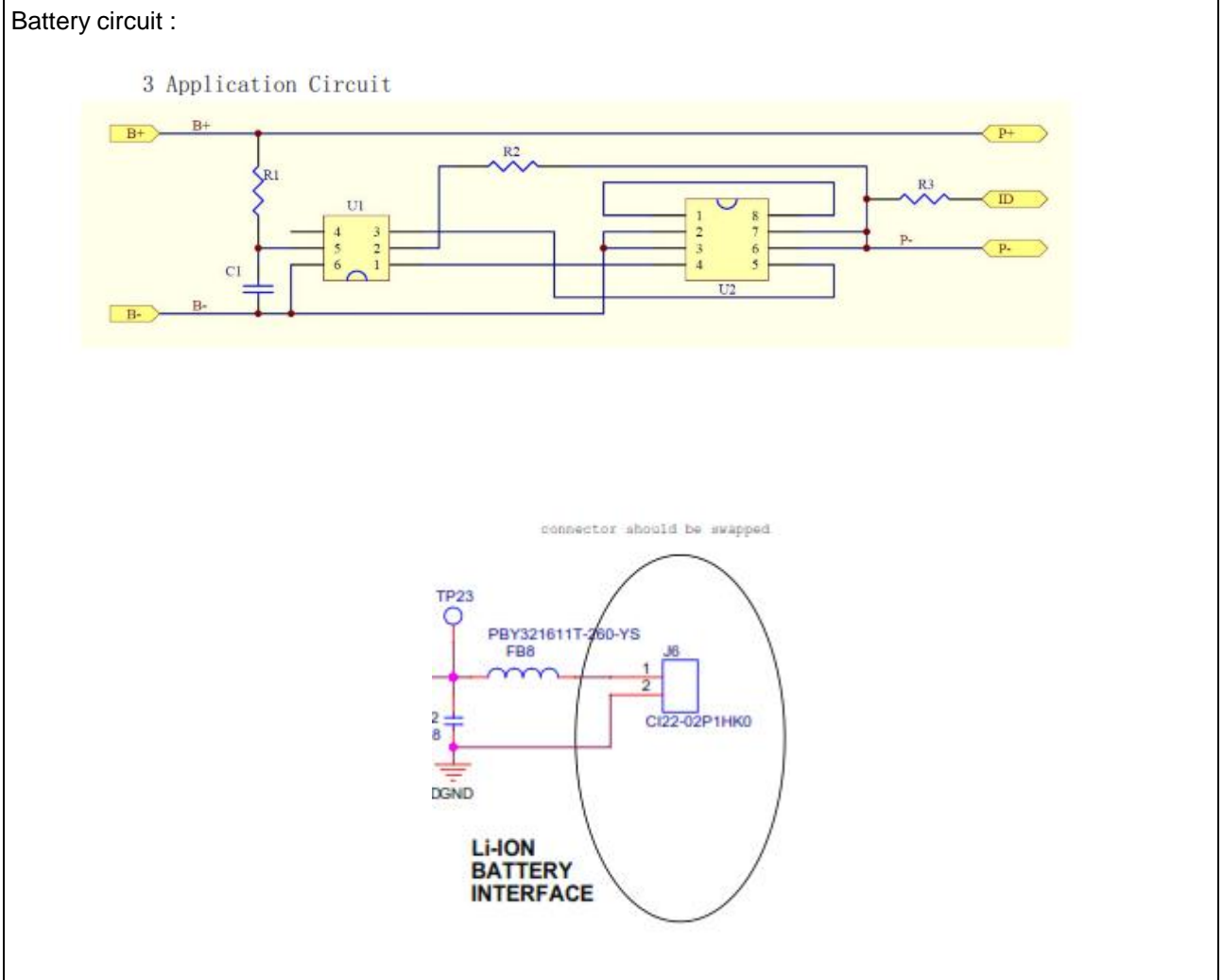

MARKINGS AND INSTRUCTIONS (1.7.13)	
Location of replaceable battery	inside the unit
Language(s)	English
Close to the battery	No
In the servicing instructions	Yes
In the operating instructions	Yes

4.5	TABLE: maximum temperatures (option 1)						P	
	test voltage (V).....	9Vdc	32Vdc				---	
	t _{amb1} (°C).....	23.0	23.1				---	
	t _{amb2} (°C).....	23.1	22.8				---	
maximum temperature T of part/at:		T (°C)				allowed T _{max} (°C)		
Cord conductors connected to PCB		38.3	40.2				62.8 (85-45+22.8)	
C30 (E.C. 85°C)		39.8	42.1				62.8 (85-45+22.8)	
Battery		30.0	32.0				42.8(65+22.8-45)	
Modem		27.2	28.5				47.8(70+22.8-45)	
PCB by U5		32.4	34.4				82.8 (105-45+22.8)	
Connector P8		29.0	31.0				62.8(85+22.8-45)	
Enclosure		26.3	27.6				47.8 (70-45+22.8)	
Supplementary information:								
Temperature T of winding:		t ₁ (°C)	R ₁ (Ω)	t ₂ (°C)	R ₂ (Ω)	T (°C)	Allowed T _{max} (°C)	Insulation class
Supplementary information:								

4.5	TABLE: maximum temperatures (option 2)							P
	test voltage (V).....:	4.2Vdc					---	
	t _{amb1} (°C).....:	23.1					---	
	t _{amb2} (°C).....:	23.3					---	
maximum temperature T of part/at:		T (°C)					allowed T _{max} (°C)	
Battery		30.4					42.3(65+23.3-45)	
Input connector		29.6					63.3(85+23.3-45)	
PCB by U5		32.4					83.3 (105-45+23.3)	
C1 (E.C. 85°C)		30.6					63.3(85-45+23.3)	
Enclosure		27.5					48.3(70-45+23.3)	
Supplementary information:								
Temperature T of winding:		t ₁ (°C)	R ₁ (Ω)	t ₂ (°C)	R ₂ (Ω)	T (°C)	Allowed T _{max} (°C)	Insulation class
Supplementary information:								

4.5.5	TABLE: Ball pressure test of thermoplastic parts			N/A
	Allowed impression diameter (mm)	≤ 2 mm		—
Part		Test temperature (°C)	Impression diameter (mm)	
Supplementary information:				

4.7	TABLE: Resistance to fire					N/A
Part	Manufacturer of material	Type of material	Thickness (mm)	Flammability class	Evidence	
Supplementary information:						

5.1	TABLE: touch current measurement			N/A
Measured between:	Measured (mA)	Limit (mA)	Comments/conditions	
supplementary information:				

5.2	TABLE: Electric strength tests, impulse tests and voltage surge tests			N/A
Test voltage applied between:	Voltage shape (AC, DC, impulse, surge)	Test voltage (V)	Breakdown Yes / No	
Functional:				
Basic/supplementary:				
Reinforced:				
Supplementary information:				

5.3		TABLE: Fault condition tests					P
		Ambient temperature (°C)					—
		Power source for EUT: Manufacturer, model/type, output rating					—
Component No.	Fault	Supply voltage (V)	Test time	Fuse #	Fuse current (A)	Observation	
Complete unit (option 1)	Opposite polarity of input power (option 1)	32Vdc	1h	-	-	No adverse effect. No fire, no hazards. After correct connection unit operated normally	
Battery pack Thinking Electronic Industrial	Short of battery pack output	4.2Vdc	1h	-	-	Internal protection operated. No fire, no hazards. After removing short battery pack operated normally	
Battery pack Thinking Electronic Industrial	Short of the first FET of PCM	4.2Vdc	1h	-	-	No fire, no hazards. Battery pack operated normally	
Battery pack Thinking Electronic Industrial	Short of the second FET of PCM	4.2Vdc	1h	-	-	No fire, no hazards. Battery pack operated normally	
Battery pack Thinking Electronic Industrial	Opened control circuit of the first FET of PCM	4.2Vdc	1h	-	-	No fire, no hazards. Battery pack operated normally	
Battery pack Thinking Electronic Industrial	Opened control circuit of the second FET of PCM	4.2Vdc	1h	-	-	No fire, no hazards. Battery pack operated normally	
Battery pack Thinking Electronic Industrial	Overcharging of fully recharged battery pack	4.2Vdc	7h	-	-	Internal protection operated. No fire, no hazards. No chemical leaks, no explosion of battery, no emission of flame or expulsion of molten metal to the outside of equipment enclosure	
Battery pack Thinking Electronic Industrial	Rapid discharge fully recharged battery pack	4.2Vdc	-	-	-	Internal protection operated. No fire, no hazards. No chemical leaks, no explosion of battery, no emission of flame or expulsion of molten metal to the outside of equipment enclosure	
Step-down converter	Short of output (C23)	5.5Vdc	-	-	-	Internal protection operated. No fire, no hazards. After removing short converter operated normally	



Battery pack GP (stand alone)	Overcharge	4.2VDC charge voltage	7h			Battery charging current goes to 0mA when battery is fully charged (charging stops)
Battery pack Yoku	Overcharge	4.2VDC charge voltage	7h			Battery charging current goes to 0mA when battery is fully charged (charging stops)
Battery pack GP	Overcharge with FET1 short-circuited	4.2VDC charge voltage	1min	---	---	No effect on normal charging process
Battery pack GP	Overcharge with FET2 short-circuited	4.2VDC charge voltage	1min	---	---	No effect on normal charging process
Battery pack Yoku	Overcharge with FET1 short-circuited	4.2VDC charge voltage	1min	---	---	No effect on normal charging process
Battery pack Yoku	Overcharge with FET1 short-circuited	4.2VDC charge voltage	1min	---	---	No effect on normal charging process
Battery pack GP	Short circuit	3.8VDC (Uoc)	1min	---		Isc = 650mA, no hazard
Battery pack Yoku	Short circuit	4.1VDC (Uoc)	1s	---		Battery pack switched off immediately
Battery pack GP fully charged until further charge stopped (no charging current observed)	FET1 was s-c	4.2Vdc	1min	---	---	Charge was not resumed
Battery pack GP fully charged until further charge stopped (no charging current observed)	FET2 was s-c	4.2Vdc	1min	---	---	Charge was not resumed



Battery pack Yoku fully charged until further charge stopped (no charging current observed)	FET1 was s-c	4.2Vdc	1min	---	---	Charge was not resumed
Battery pack Yoku fully charged until further charge stopped (no charging current observed)	FET2 was s-c	4.2Vdc	1min	---	---	Charge was not resumed
Supplementary information:						

C.2		TABLE: transformers					N/A	
Loc.	Tested insulation	Working voltage peak / V (2.10.2)	Working voltage rms / V (2.10.2)	Required electric strength (5.2)	Required clearance / mm (2.10.3)	Required creepage distance / mm (2.10.4)	Required distance thr. insul. (2.10.5)	
Loc.	Tested insulation			Test voltage / V	Measured clearance / mm	Measured creepage dist. / mm	Measured distance thr. insul. / mm; number of layers	
supplementary information:								

C.2	TABLE: transformers	N/A
Transformer		

List of test equipment used:

(Note: This is an example of the required attachment. Other forms with a different layout but containing similar information are also acceptable.)

ITL	Instrument	Manufacturer	Model	Serial	CallDue
1140	Digital Timer	Golf	Timer	/	28/02/2013
1302	Digital Thermometer	Fluke	Hydra 2635A	692300	28/02/2013

Appendix 1 – Photographs

Picture 1. EUT isometric views (option 1)



Picture 2. EUT isometric views (option 2)



Picture 3. Option 2 internal view



Picture 4. Internal View – GP battery



Picture 5. Internal View – Yoku battery





Cello Track 3G-power





Internal view





appendix 2 - National Differences

ATTACHMENT TO TEST REPORT IEC 60950-1	
EUROPEAN GROUP DIFFERENCES AND NATIONAL DIFFERENCES	
Information technology equipment – Safety –	
Part 1: General requirements	
Differences according to	EN 60950-1:2006/A11:2009/A1:2010
Attachment Form No.	EU_GD_IEC60950_1C
Attachment Originator	SGS Fimko Ltd
Master Attachment	Date (2010-04)
Copyright © 2010 IEC System for Conformity Testing and Certification of Electrical Equipment (IECEE), Geneva, Switzerland. All rights reserved.	

EN 60950-1:2006/A11:2009/A1:2010 – CENELEC COMMON MODIFICATIONS
--

IEC 60950-1, GROUP DIFFERENCES (CENELEC common modifications EN)			
Clause	Requirement + Test	Result - Remark	Verdict
Contents	Add the following annexes: Annex ZA (normative) Normative references to international publications with their corresponding European publications Annex ZB (normative) Special national conditions		P
General	Delete all the “country” notes in the reference document (IEC 60950-1:2005) according to the following list: 1.4.8 Note 2 1.5.1 Note 2 & 3 1.5.7.1 Note 1.5.8 Note 2 1.5.9.4 Note 1.7.2.1 Note 4, 5 & 6 2.2.3 Note 2.2.4 Note 2.3.2 Note 2.3.2.1 Note 2 2.3.4 Note 2 2.6.3.3 Note 2 & 3 2.7.1 Note 2.10.3.2 Note 2 2.10.5.13 Note 3 3.2.1.1 Note 3.2.4 Note 3. 2.5.1 Note 2 4.3.6 Note 1 & 2 4.7 Note 4 4.7.2.2 Note 4.7.3.1 Note 2 5.1.7.1 Note 3 & 4 5.3.7 Note 1 6 Note 2 & 5 6.1.2.1 Note 2 6.1.2.2 Note 6.2.2 Note 6.2.2.1 Note 2 6.2.2.2 Note 7.1 Note 3 7.2 Note 7.3 Note 1 & 2 G.2.1 Note 2 Annex H Note 2		P
General (A1:2010)	Delete all the “country” notes in the reference document (IEC 60950-1:2005/A1:2010) according to the following list: 1.5.7.1 Note 6.1.2.1 Note 2 6.2.2.1 Note 2 EE.3 Note		P



IEC 60950-1, GROUP DIFFERENCES (CENELEC common modifications EN)			
Clause	Requirement + Test	Result - Remark	Verdict
1.3.Z1	<p>Add the following subclause:</p> <p>1.3.Z1 Exposure to excessive sound pressure</p> <p>The apparatus shall be so designed and constructed as to present no danger when used for its intended purpose, either in normal operating conditions or under fault conditions, particularly providing protection against exposure to excessive sound pressures from headphones or earphones.</p> <p>NOTE Z1 A new method of measurement is described in EN 50332-1, Sound system equipment: Headphones and earphones associated with portable audio equipment - Maximum sound pressure level measurement methodology and limit considerations - Part 1: General method for "one package equipment", and in EN 50332-2, Sound system equipment: Headphones and earphones associated with portable audio equipment - Maximum sound pressure level measurement methodology and limit considerations - Part 2: Guidelines to associate sets with headphones coming from different manufacturers.</p>	<p>Class III</p> <p>Added</p>	P
1.5.1	<p>Add the following NOTE:</p> <p>NOTE Z1 The use of certain substances in electrical and electronic equipment is restricted within the EU: see Directive 2002/95/EC</p>	Added	P
1.7.2.1 (A1:2010)	<p>In addition, for a PORTABLE SOUND SYSTEM, the instructions shall include a warning that excessive sound pressure from earphones and headphones can cause hearing loss.</p>	No such unit	N/A

IEC 60950-1, GROUP DIFFERENCES (CENELEC common modifications EN)			
Clause	Requirement + Test	Result - Remark	Verdict
2.7.1	<p>Replace the subclause as follows:</p> <p>Basic requirements</p> <p>To protect against excessive current, short-circuits and earth faults in PRIMARY CIRCUITS, protective devices shall be included either as integral parts of the equipment or as parts of the building installation, subject to the following, a), b) and c):</p> <p>a) except as detailed in b) and c), protective devices necessary to comply with the requirements of 5.3 shall be included as parts of the equipment;</p> <p>b) for components in series with the mains input to the equipment such as the supply cord, appliance coupler, r.f.i. filter and switch, short-circuit and earth fault protection may be provided by protective devices in the building installation;</p>	Replaced	N/A
	<p>c) it is permitted for PLUGGABLE EQUIPMENT TYPE B or PERMANENTLY CONNECTED EQUIPMENT, to rely on dedicated overcurrent and short-circuit protection in the building installation, provided that the means of protection, e.g. fuses or circuit breakers, is fully specified in the installation instructions.</p> <p>If reliance is placed on protection in the building installation, the installation instructions shall so state, except that for PLUGGABLE EQUIPMENT TYPE A the building installation shall be regarded as providing protection in accordance with the rating of the wall socket outlet.</p>	Class III	N/A
2.7.2	This subclause has been declared 'void'.	Voided	P
3.2.3	Delete the NOTE in Table 3A, and delete also in this table the conduit sizes in parentheses.	Deleted	P

IEC 60950-1, GROUP DIFFERENCES (CENELEC common modifications EN)			
Clause	Requirement + Test	Result - Remark	Verdict
3.2.5.1	<p>Replace "60245 IEC 53" by "H05 RR-F"; "60227 IEC 52" by "H03 VV-F or H03 VVH2-F"; "60227 IEC 53" by "H05 VV-F or H05 VVH2-F2".</p> <p>In Table 3B, replace the first four lines by the following:</p> <p>Up to and including 6 0,75^{a)} Over 6 up to and including 10 (0,75)^{b)} 1,0 Over 10 up to and including 16 (1,0)^{c)} 1,5 </p> <p>In the conditions applicable to Table 3B delete the words "in some countries" in condition^{a)}.</p> <p>In NOTE 1, applicable to Table 3B, delete the second sentence.</p>	<p>Replaced Class III</p>	N/A
3.3.4	<p>In Table 3D, delete the fourth line: conductor sizes for 10 to 13 A, and replace with the following:</p> <p>Over 10 up to and including 16 1,5 to 2,5 1,5 to 4 </p> <p>Delete the fifth line: conductor sizes for 13 to 16 A</p>	<p>Deleted Class III</p>	N/A
4.3.13.6 (A1:2010)	<p>Replace the existing NOTE by the following:</p> <p>NOTE Z1 Attention is drawn to:</p> <p>1999/519/EC: Council Recommendation on the limitation of exposure of the general public to electromagnetic fields 0 Hz to 300 GHz, and</p> <p>2006/25/EC: Directive on the minimum health and safety requirements regarding the exposure of workers to risks arising from physical agents (artificial optical radiation).</p>	<p>Replaced Class III</p>	N/A
	<p>Standards taking into account mentioned Recommendation and Directive which demonstrate compliance with the applicable EU Directive are indicated in the OJEC.</p>		N/A
Annex H	<p>Replace the last paragraph of this annex by:</p> <p>At any point 10 cm from the surface of the OPERATOR ACCESS AREA, the dose rate shall not exceed 1 μSv/h (0,1 mR/h) (see NOTE). Account is taken of the background level.</p> <p>Replace the notes as follows:</p> <p>NOTE These values appear in Directive 96/29/Euratom. Delete NOTE 2.</p>	<p>Replaced</p>	P
Bibliography	<p>Additional EN standards.</p>		—



IEC 60950-1, GROUP DIFFERENCES (CENELEC common modifications EN)			
Clause	Requirement + Test	Result - Remark	Verdict

ZA	NORMATIVE REFERENCES TO INTERNATIONAL PUBLICATIONS WITH THEIR CORRESPONDING EUROPEAN PUBLICATIONS		—
-----------	--	--	---

<p align="center">ZB ANNEX (normative)</p> <p align="center">SPECIAL NATIONAL CONDITIONS (EN)</p>			
Clause	Requirement + Test	Result - Remark	Verdict
1.2.4.1	In Denmark , certain types of Class I appliances (see 3.2.1.1) may be provided with a plug not establishing earthing conditions when inserted into Danish socket-outlets.	Class III	N/A
1.2.13.14	In Norway and Sweden , for requirements see 1.7.2.1 and 7.3 of this annex.	Class III	N/A
1.5.7.1	In Finland, Norway and Sweden , resistors bridging BASIC INSULATION in CLASS I PLUGGABLE EQUIPMENT TYPE A must comply with the requirements in 1.5.7.1. In addition when a single resistor is used, the resistor must withstand the resistor test in 1.5.7.2.	Class III	N/A
1.5.8	In Norway , due to the IT power system used (see annex V, Figure V.7), capacitors are required to be rated for the applicable line-to-line voltage (230 V).	Class III	N/A
1.5.9.4	In Finland, Norway and Sweden , the third dashed sentence is applicable only to equipment as defined in 6.1.2.2 of this annex.	Class III	N/A

ZB ANNEX (normative)

SPECIAL NATIONAL CONDITIONS (EN)

Clause	Requirement + Test	Result - Remark	Verdict
1.7.2.1	<p>In Finland, Norway and Sweden, CLASS I PLUGGABLE EQUIPMENT TYPE A intended for connection to other equipment or a network shall, if safety relies on connection to protective earth or if surge suppressors are connected between the network terminals and accessible parts, have a marking stating that the equipment must be connected to an earthed mains socket-outlet.</p> <p>The marking text in the applicable countries shall be as follows:</p> <p>In Finland: "Laitte on liitettävä suojakoskettimilla varustettuun pistorasiaan"</p> <p>In Norway: "Apparatet må tilkoples jordet stikkontakt"</p> <p>In Sweden: "Apparaten skall anslutas till jordat uttag"</p> <p>In Norway and Sweden, the screen of the cable distribution system is normally not earthed at the entrance of the building and there is normally no equipotential bonding system within the building. Therefore the protective earthing of the building installation need to be isolated from the screen of a cable distribution system.</p> <p>It is however accepted to provide the insulation external to the equipment by an adapter or an interconnection cable with galvanic isolator, which may be provided by e.g. a retailer.</p> <p>The user manual shall then have the following or similar information in Norwegian and Swedish language respectively, depending on in what country the equipment is intended to be used in:</p> <p>"Equipment connected to the protective earthing of the building installation through the mains connection or through other equipment with a connection to protective earthing – and to a cable distribution system using coaxial cable, may in some circumstances create a fire hazard. Connection to a cable distribution system has therefore to be provided through a device providing electrical isolation below a certain frequency range (galvanic isolator, see EN 60728-11)."</p>	Class III	N/A

ZB ANNEX (normative)			
SPECIAL NATIONAL CONDITIONS (EN)			
Clause	Requirement + Test	Result - Remark	Verdict
	<p>NOTE In Norway, due to regulation for installations of cable distribution systems, and in Sweden, a galvanic isolator shall provide electrical insulation below 5 MHz. The insulation shall withstand a dielectric strength of 1,5 kV r.m.s., 50 Hz or 60 Hz, for 1 min.</p> <p>Translation to Norwegian (the Swedish text will also be accepted in Norway):</p> <p>“Utstyr som er koplet til beskyttelsesjord via nettplugg og/eller via annet jordtilkoplet utstyr – og er tilkoplet et kabel-TV nett, kan forårsake brannfare. For å unngå dette skal det ved tilkopling av utstyret til kabel-TV nettet installeres en galvanisk isolator mellom utstyret og kabel- TV nettet.”</p> <p>Translation to Swedish:</p> <p>”Utrustning som är kopplad till skyddsjord via jordat vägguttag och/eller via annan utrustning och samtidigt är kopplad till kabel-TV nät kan i vissa fall medföra risk för brand. För att undvika detta skall vid anslutning av utrustningen till kabel-TV nät galvanisk isolator finnas mellan utrustningen och kabel-TV nätet.”</p>	Class III	N/A
1.7.5	<p>In Denmark, socket-outlets for providing power to other equipment shall be in accordance with the Heavy Current Regulations, Section 107-2-D1, Standard Sheet DK 1-3a, DK 1-5a or DK 1-7a, when used on Class I equipment. For STATIONARY EQUIPMENT the socket-outlet shall be in accordance with Standard Sheet DK 1-1b or DK 1-5a.</p> <p>For CLASS II EQUIPMENT the socket outlet shall be in accordance with Standard Sheet DKA 1-4a.</p>	Class III	N/A
2.2.4	<p>In Norway, for requirements see 1.7.2.1, 6.1.2.1 and 6.1.2.2 of this annex.</p>	Class III	N/A
2.3.2	<p>In Finland, Norway and Sweden there are additional requirements for the insulation. See 6.1.2.1 and 6.1.2.2 of this annex.</p>	Class III	N/A
2.3.4	<p>In Norway, for requirements see 1.7.2.1, 6.1.2.1 and 6.1.2.2 of this annex.</p>	Class III	N/A



ZB ANNEX (normative)			
SPECIAL NATIONAL CONDITIONS (EN)			
Clause	Requirement + Test	Result - Remark	Verdict
2.6.3.3	In the United Kingdom , the current rating of the circuit shall be taken as 13 A, not 16 A.	Class III	N/A
2.7.1	In the United Kingdom , to protect against excessive currents and short-circuits in the PRIMARY CIRCUIT of DIRECT PLUG-IN EQUIPMENT, tests according to 5.3 shall be conducted, using an external protective device rated 30 A or 32 A. If these tests fail, suitable protective devices shall be included as integral parts of the DIRECT PLUG-IN EQUIPMENT, so that the requirements of 5.3 are met.	Class III	N/A
2.10.5.13	In Finland, Norway and Sweden , there are additional requirements for the insulation, see 6.1.2.1 and 6.1.2.2 of this annex.	Class III	N/A



3.2.1.1	<p>In Switzerland, supply cords of equipment having a RATED CURRENT not exceeding 10 A shall be provided with a plug complying with SEV 1011 or IEC 60884-1 and one of the following dimension sheets:</p> <p>SEV 6532-2.1991 Plug Type 15 3P+N+PE 250/400 V, 10 A</p> <p>SEV 6533-2.1991 Plug Type 11 L+N 250 V, 10 A</p> <p>SEV 6534-2.1991 Plug Type 12 L+N+PE 250 V, 10 A</p> <p>In general, EN 60309 applies for plugs for currents exceeding 10 A. However, a 16 A plug and socket-outlet system is being introduced in Switzerland, the plugs of which are according to the following dimension sheets, published in February 1998:</p> <p>SEV 5932-2.1998: Plug Type 25 , 3L+N+PE 230/400 V, 16 A</p> <p>SEV 5933-2.1998: Plug Type 21, L+N, 250 V, 16A</p> <p>SEV 5934-2.1998: Plug Type 23, L+N+PE .250 V, 16 A</p>	Class III	N/A
3.2.1.1	<p>In Denmark, supply cords of single-phase equipment having a rated current not exceeding 13 A shall be provided with a plug according to the Heavy Current Regulations, Section 107-2-D1.</p> <p>CLASS I EQUIPMENT provided with socket-outlets with earth contacts or which are intended to be used in locations where protection against indirect contact is required according to the wiring rules shall be provided with a plug in accordance with standard sheet DK 2-1a or DK 2-5a.</p> <p>If poly-phase equipment and single-phase equipment having a RATED CURRENT exceeding 13 A is provided with a supply cord with a plug, this plug shall be in accordance with the Heavy Current Regulations, Section 107-2-D1 or EN 60309-2.</p>	Class III	N/A



3.2.1.1	<p>In Spain, supply cords of single-phase equipment having a rated current not exceeding 10 A shall be provided with a plug according to UNE 20315:1994.</p> <p>Supply cords of single-phase equipment having a rated current not exceeding 2,5 A shall be provided with a plug according to UNE-EN 50075:1993.</p> <p>CLASS I EQUIPMENT provided with socket-outlets with earth contacts or which are intended to be used in locations where protection against indirect contact is required according to the wiring rules, shall be provided with a plug in accordance with standard UNE 20315:1994.</p> <p>If poly-phase equipment is provided with a supply cord with a plug, this plug shall be in accordance with UNE-EN 60309-2.</p>	Class III	N/A
3.2.1.1	<p>In the United Kingdom, apparatus which is fitted with a flexible cable or cord and is designed to be connected to a mains socket conforming to BS 1363 by means of that flexible cable or cord and plug, shall be fitted with a 'standard plug' in accordance with Statutory Instrument 1768:1994 - The Plugs and Sockets etc. (Safety) Regulations 1994, unless exempted by those regulations.</p> <p>NOTE 'Standard plug' is defined in SI 1768:1994 and essentially means an approved plug conforming to BS 1363 or an approved conversion plug.</p>	Class III	N/A
3.2.1.1	<p>In Ireland, apparatus which is fitted with a flexible cable or cord and is designed to be connected to a mains socket conforming to I.S. 411 by means of that flexible cable or cord and plug, shall be fitted with a 13 A plug in accordance with Statutory Instrument 525:1997 - National Standards Authority of Ireland (section 28) (13 A Plugs and Conversion Adaptors for Domestic Use) Regulations 1997.</p>	Class III	N/A
3.2.4	<p>In Switzerland, for requirements see 3.2.1.1 of this annex.</p>	Class III	N/A
3.2.5.1	<p>In the United Kingdom, a power supply cord with conductor of 1,25 mm² is allowed for equipment with a rated current over 10 A and up to and including 13 A.</p>	Class III	N/A

3.3.4	<p>In the United Kingdom, the range of conductor sizes of flexible cords to be accepted by terminals for equipment with a RATED CURRENT of over 10 A up to and including 13 A is:</p> <ul style="list-style-type: none"> • 1,25 mm² to 1,5 mm² nominal cross-sectional area. 	Class III	N/A
4.3.6	<p>In the United Kingdom, the torque test is performed using a socket outlet complying with BS 1363 part 1:1995, including Amendment 1:1997 and Amendment 2:2003 and the plug part of DIRECT PLUG-IN EQUIPMENT shall be assessed to BS 1363: Part 1, 12.1, 12.2, 12.3, 12.9, 12.11, 12.12, 12.13, 12.16 and 12.17, except that the test of 12.17 is performed at not less than 125 °C. Where the metal earth pin is replaced by an Insulated Shutter Opening Device (ISOD), the requirements of clauses 22.2 and 23 also apply.</p>	Class III	N/A
4.3.6	<p>In Ireland, DIRECT PLUG-IN EQUIPMENT is known as plug similar devices. Such devices shall comply with Statutory Instrument 526:1997 - National Standards Authority of Ireland (Section 28) (Electrical plugs, plug similar devices and sockets for domestic use) Regulations, 1997.</p>	Class III	N/A
5.1.7.1	<p>In Finland, Norway and Sweden TOUCH CURRENT measurement results exceeding 3,5 mA r.m.s. are permitted only for the following equipment:</p> <ul style="list-style-type: none"> • STATIONARY PLUGGABLE EQUIPMENT TYPE A that <ul style="list-style-type: none"> is intended to be used in a RESTRICTED ACCESS LOCATION where equipotential bonding has been applied, for example, in a telecommunication centre; and has provision for a permanently connected PROTECTIVE EARTHING CONDUCTOR; and is provided with instructions for the installation of that conductor by a SERVICE PERSON; • STATIONARY PLUGGABLE EQUIPMENT TYPE B; • STATIONARY PERMANENTLY CONNECTED EQUIPMENT. 	Class III	N/A



<p>6.1.2.1 (A1:2010)</p>	<p>In Finland, Norway and Sweden, add the following text between the first and second paragraph of the compliance clause:</p> <p>If this insulation is solid, including insulation forming part of a component, it shall at least consist of either</p> <ul style="list-style-type: none">- two layers of thin sheet material, each of which shall pass the electric strength test below, or- one layer having a distance through insulation of at least 0,4 mm, which shall pass the electric strength test below. <p>Alternatively for components, there is no distance through insulation requirements for the insulation consisting of an insulating compound completely filling the casing, so that CLEARANCES and CREEPAGE DISTANCES do not exist, if the component passes the electric strength test in accordance with the compliance clause below and in addition</p> <ul style="list-style-type: none">- passes the tests and inspection criteria of 2.10.11 with an electric strength test of 1,5 kV multiplied by 1,6 (the electric strength test of 2.10.10 shall be performed using 1,5 kV), and- is subject to ROUTINE TESTING for electric strength during manufacturing, using a test voltage of 1,5 kV.	<p>Class III</p>	<p>N/A</p>
------------------------------	--	------------------	------------



	<p>It is permitted to bridge this insulation with an optocoupler complying with 2.10.5.4 b).</p> <p>It is permitted to bridge this insulation with a capacitor complying with EN 60384-14:2005, subclass Y2.</p> <p>A capacitor classified Y3 according to EN 60384-14:2005, may bridge this insulation under the following conditions:</p> <ul style="list-style-type: none"> - the insulation requirements are satisfied by having a capacitor classified Y3 as defined by EN 60384-14, which in addition to the Y3 testing, is tested with an impulse test of 2,5 kV defined in EN 60950-1:2006, 6.2.2.1; - the additional testing shall be performed on all the test specimens as described in EN 60384-14; - the impulse test of 2,5 kV is to be performed before the endurance test in EN 60384-14, in the sequence of tests as described in EN 60384-14. 	Class III	N/A
6.1.2.2	<p>In Finland, Norway and Sweden, the exclusions are applicable for PERMANENTLY CONNECTED EQUIPMENT, PLUGGABLE EQUIPMENT TYPE B and equipment intended to be used in a RESTRICTED ACCESS LOCATION where equipotential bonding has been applied, e.g. in a telecommunication centre, and which has provision for a permanently connected PROTECTIVE EARTHING CONDUCTOR and is provided with instructions for the installation of that conductor by a SERVICE PERSON.</p>	Class III	N/A
7.2	<p>In Finland, Norway and Sweden, for requirements see 6.1.2.1 and 6.1.2.2 of this annex.</p> <p>The term TELECOMMUNICATION NETWORK in 6.1.2 being replaced by the term CABLE DISTRIBUTION SYSTEM.</p>	No Such connection	N/A
7.3	<p>In Norway and Sweden, for requirements see 1.2.13.14 and 1.7.2.1 of this annex.</p>	As above	N/A
7.3	<p>In Norway, for installation conditions see EN 60728-11:2005.</p>		N/A



**ATTACHMENT TO TEST REPORT IEC 60950-1
EUROPEAN GROUP DIFFERENCES AND NATIONAL DIFFERENCES**

Information technology equipment – Safety –

Part 1: General requirements

Differences according to: EN 60950-1:2006/A11:2009/A1:2010/A12:2011

Attachment Form No.: EU_GD_IEC60950_1C_II

Attachment Originator: SGS Fimko Ltd

Master Attachment: Date 2011-08

Copyright © 2011 IEC System for Conformity Testing and Certification of Electrical Equipment (IECEE), Geneva, Switzerland. All rights reserved.

EN 60950-1:2006/A11:2009/A1:2010/A12:2011 – CENELEC COMMON MODIFICATIONS

IEC 60950-1, GROUP DIFFERENCES (CENELEC common modifications EN)

Clause	Requirement + Test	Result - Remark	Verdict
Contents	Add the following annexes: Annex ZA (normative) Normative references to international publications with their corresponding European publications Annex ZB (normative) Special national conditions		P
General	Delete all the "country" notes in the reference document (IEC 60950-1:2005) according to the following list: 1.4.8 Note 2 1.5.1 Note 2 & 3 1.5.7.1 Note 1.5.8 Note 2 1.5.9.4 Note 1.7.2.1 Note 4, 5 & 6 2.2.3 Note 2.2.4 Note 2.3.2 Note 2.3.2.1 Note 2 2.3.4 Note 2 2.6.3.3 Note 2 & 3 2.7.1 Note 2.10.3.2 Note 2 2.10.5.13 Note 3 3.2.1.1 Note 3.2.4 Note 3. 2.5.1 Note 2 4.3.6 Note 1 & 2 4.7 Note 4 4.7.2.2 Note 4.7.3.1 Note 2 5.1.7.1 Note 3 & 4 5.3.7 Note 1 6 Note 2 & 5 6.1.2.1 Note 2 6.1.2.2 Note 6.2.2 Note 6.2.2.1 Note 2 6.2.2.2 Note 7.1 Note 3 7.2 Note 7.3 Note 1 & 2 G.2.1 Note 2 Annex H Note 2		P
General (A1:2010)	Delete all the "country" notes in the reference document (IEC 60950-1:2005/A1:2010) according to the following list: 1.5.7.1 Note 6.1.2.1 Note 2 6.2.2.1 Note 2 EE.3 Note		P



IEC 60950-1, GROUP DIFFERENCES (CENELEC common modifications EN)			
Clause	Requirement + Test	Result - Remark	Verdict
1.3.Z1	<p>Add the following subclause:</p> <p>1.3.Z1 Exposure to excessive sound pressure</p> <p>The apparatus shall be so designed and constructed as to present no danger when used for its intended purpose, either in normal operating conditions or under fault conditions, particularly providing protection against exposure to excessive sound pressures from headphones or earphones.</p> <p>NOTE Z1 A new method of measurement is described in EN 50332-1, Sound system equipment: Headphones and earphones associated with portable audio equipment - Maximum sound pressure level measurement methodology and limit considerations - Part 1: General method for "one package equipment", and in EN 50332-2, Sound system equipment: Headphones and earphones associated with portable audio equipment - Maximum sound pressure level measurement methodology and limit considerations - Part 2: Guidelines to associate sets with headphones coming from different manufacturers.</p>	Added	P
(A12:2011)	<p>In EN 60950-1:2006/A12:2011</p> <p>Delete the addition of 1.3.Z1 / EN 60950-1:2006</p> <p>Delete the definition 1.2.3.Z1 / EN 60950-1:2006 /A1:2010</p>	Deleted	P
1.5.1	<p>Add the following NOTE:</p> <p>NOTE Z1 The use of certain substances in electrical and electronic equipment is restricted within the EU: see Directive 2002/95/EC</p>	Added	N/A
1.7.2.1 (A1:2010)	<p>In addition, for a PORTABLE SOUND SYSTEM, the instructions shall include a warning that excessive sound pressure from earphones and headphones can cause hearing loss.</p>		N/A
1.7.2.1 (A12:2011)	<p>In EN 60950-1:2006/A12:2011</p> <p>Delete NOTE Z1 and the addition for Portable Sound System.</p> <p>Add the following clause and annex to the existing standard and amendments.</p>		

	<p>Zx Protection against excessive sound pressure from personal music players</p>	<p>N/A</p>
	<p>Zx.1 General This sub-clause specifies requirements for protection against excessive sound pressure from personal music players that are closely coupled to the ear. It also specifies requirements for earphones and headphones intended for use with personal music players.</p> <p>A personal music player is a portable equipment for personal use, that:</p> <ul style="list-style-type: none"> – is designed to allow the user to listen to recorded or broadcast sound or video; and – primarily uses headphones or earphones that can be worn in or on or around the ears; and – allows the user to walk around while in use. <p>NOTE 1 Examples are hand-held or body-worn portable CD players, MP3 audio players, mobile phones with MP3 type features, PDA's or similar equipment.</p> <p>A personal music player and earphones or headphones intended to be used with personal music players shall comply with the requirements of this sub-clause.</p> <p>The requirements in this sub-clause are valid for music or video mode only.</p> <p>The requirements do not apply:</p> <ul style="list-style-type: none"> – while the personal music player is connected to an external amplifier; or – while the headphones or earphones are not used. <p>NOTE 2 An external amplifier is an amplifier which is not part of the personal music player or the listening device, but which is intended to play the music as a standalone music player.</p> <p>The requirements do not apply to:</p> <ul style="list-style-type: none"> – hearing aid equipment and professional equipment; <p>NOTE 3 Professional equipment is equipment sold through special sales channels. All products sold through normal electronics stores are considered not to be professional equipment.</p>	<p>N/A</p>
	<ul style="list-style-type: none"> – analogue personal music players (personal music players without any kind of digital processing of the sound signal) that are brought to the market before the end of 2015. <p>NOTE 4 This exemption has been allowed because this technology is falling out of use and it is expected that within a few years it will no longer exist. This exemption will not be extended to other technologies.</p> <p>For equipment which is clearly designed or intended for use by young children, the limits of EN 71-1 apply.</p>	<p>N/A</p>



	<p>Zx.2 Equipment requirements No safety provision is required for equipment that complies with the following:</p> <ul style="list-style-type: none">– equipment provided as a package (personal music player with its listening device), where the acoustic output $L_{Aeq,T}$ is 85 dBA measured while playing the fixed “programme simulation noise” as described in EN 50332-1; and– a personal music player provided with an analogue electrical output socket for a listening device, where the electrical output is 27 mV measured as described in EN 50332-2, while playing the fixed “programme simulation noise” as described in EN 50332-1. <p>NOTE 1 Wherever the term acoustic output is used in this clause, the 30 s A-weighted equivalent sound pressure level $L_{Aeq,T}$ is meant. See also Zx.5 and Annex Zx.</p> <p>All other equipment shall:</p> <ol style="list-style-type: none">a) protect the user from unintentional acoustic outputs exceeding those mentioned above; andb) have a standard acoustic output level not exceeding those mentioned above, and automatically return to an output level not exceeding those mentioned above when the power is switched off; and		N/A
--	---	--	-----

	<p>c) provide a means to actively inform the user of the increased sound pressure when the equipment is operated with an acoustic output exceeding those mentioned above. Any means used shall be acknowledged by the user before activating a mode of operation which allows for an acoustic output exceeding those mentioned above. The acknowledgement does not need to be repeated more than once every 20 h of cumulative listening time; and</p> <p>NOTE 2 Examples of means include visual or audible signals. Action from the user is always required.</p> <p>NOTE 3 The 20 h listening time is the accumulative listening time, independent how often and how long the personal music player has been switched off.</p> <p>d) have a warning as specified in Zx.3; and</p> <p>e) not exceed the following:</p> <ol style="list-style-type: none"> 1) equipment provided as a package (player with its listening device), the acoustic output shall be 100 dBA measured while playing the fixed "programme simulation noise" described in EN 50332-1; and 2) a personal music player provided with an analogue electrical output socket for a listening device, the electrical output shall be 150 mV measured as described in EN 50332-2, while playing the fixed "programme simulation noise" described in EN 50332-1. <p>For music where the average sound pressure (long term $L_{Aeq,T}$) measured over the duration of the song is lower than the average produced by the programme simulation noise, the warning does not need to be given as long as the average sound pressure of the song is below the basic limit of 85 dBA. In this case T becomes the duration of the song.</p> <p>NOTE 4 Classical music typically has an average sound pressure (long term $L_{Aeq,T}$) which is much lower than the average programme simulation noise. Therefore, if the player is capable to analyse the song and compare it with the programme simulation noise, the warning does not need to be given as long as the average sound pressure of the song is below the basic limit of 85 dBA.</p> <p>For example, if the player is set with the programme simulation noise to 85 dBA, but the average music level of the song is only 65 dBA, there is no need to give a warning or ask an acknowledgement as long as the average sound level of the song is not above the basic limit of 85 dBA.</p>		<p>N/A</p>
--	---	--	------------

	<p>Zx.3 Warning The warning shall be placed on the equipment, or on the packaging, or in the instruction manual and shall consist of the following:</p> <ul style="list-style-type: none"> – the symbol of Figure 1 with a minimum height of 5 mm; and – the following wording, or similar: <p>“To prevent possible hearing damage, do not listen at high volume levels for long periods.”</p> <div style="text-align: center;">  </div> <p>Figure 1 – Warning label (IEC 60417-6044)</p> <p>Alternatively, the entire warning may be given through the equipment display during use, when the user is asked to acknowledge activation of the higher level.</p>		N/A
	<p>Zx.4 Requirements for listening devices (headphones and earphones)</p>		N/A
	<p>Zx.4.1 Wired listening devices with analogue input With 94 dBA sound pressure output $L_{Aeq,T}$, the input voltage of the fixed “programme simulation noise” described in EN 50332-2 shall be 75 mV.</p> <p>This requirement is applicable in any mode where the headphones can operate (active or passive), including any available setting (for example built-in volume level control).</p> <p>NOTE The values of 94 dBA – 75 mV correspond with 85dBA – 27 mV and 100 dBA – 150 mV.</p>		N/A
	<p>Zx.4.2 Wired listening devices with digital input With any playing device playing the fixed “programme simulation noise” described in EN 50332-1 (and respecting the digital interface standards, where a digital interface standard exists that specifies the equivalent acoustic level), the acoustic output $L_{Aeq,T}$ of the listening device shall be 100 dBA.</p> <p>This requirement is applicable in any mode where the headphones can operate, including any available setting (for example built-in volume level control, additional sound feature like equalization, etc.).</p> <p>NOTE An example of a wired listening device with digital input is a USB headphone.</p>		N/A

	<p>Zx.4.3 Wireless listening devices In wireless mode:</p> <ul style="list-style-type: none"> – with any playing and transmitting device playing the fixed programme simulation noise described in EN 50332-1; and – respecting the wireless transmission standards, where an air interface standard exists that specifies the equivalent acoustic level; and – with volume and sound settings in the listening device (for example built-in volume level control, additional sound feature like equalization, etc.) set to the combination of positions that maximize the measured acoustic output for the abovementioned programme simulation noise, the acoustic output $L_{Aeq,T}$ of the listening device shall be 100 dBA. <p>NOTE An example of a wireless listening device is a Bluetooth headphone.</p>		N/A
	<p>Zx.5 Measurement methods Measurements shall be made in accordance with EN 50332-1 or EN 50332-2 as applicable. Unless stated otherwise, the time interval T shall be 30 s.</p> <p>NOTE Test method for wireless equipment provided without listening device should be defined.</p>		N/A
2.7.1	<p>Replace the subclause as follows: Basic requirements</p> <p>To protect against excessive current, short-circuits and earth faults in PRIMARY CIRCUITS, protective devices shall be included either as integral parts of the equipment or as parts of the building installation, subject to the following, a), b) and c):</p> <p>a) except as detailed in b) and c), protective devices necessary to comply with the requirements of 5.3 shall be included as parts of the equipment;</p> <p>b) for components in series with the mains input to the equipment such as the supply cord, appliance coupler, r.f.i. filter and switch, short-circuit and earth fault protection may be provided by protective devices in the building installation;</p>	Replaced	N/A

	<p>c) it is permitted for PLUGGABLE EQUIPMENT TYPE B or PERMANENTLY CONNECTED EQUIPMENT, to rely on dedicated overcurrent and short-circuit protection in the building installation, provided that the means of protection, e.g. fuses or circuit breakers, is fully specified in the installation instructions.</p> <p>If reliance is placed on protection in the building installation, the installation instructions shall so state, except that for PLUGGABLE EQUIPMENT TYPE A the building installation shall be regarded as providing protection in accordance with the rating of the wall socket outlet.</p>	Replaced	N/A						
2.7.2	This subclause has been declared 'void'.	Voided	N/A						
3.2.3	Delete the NOTE in Table 3A, and delete also in this table the conduit sizes in parentheses.	Deleted	N/A						
3.2.5.1	<p>Replace "60245 IEC 53" by "H05 RR-F"; "60227 IEC 52" by "H03 VV-F or H03 VVH2-F"; "60227 IEC 53" by "H05 VV-F or H05 VVH2-F2".</p> <p>In Table 3B, replace the first four lines by the following:</p> <table style="margin-left: 40px;"> <tr> <td>Up to and including 6 </td> <td>0,75^{a)} </td> </tr> <tr> <td>Over 6 up to and including 10 (0,75)^{b)}</td> <td>1,0 </td> </tr> <tr> <td>Over 10 up to and including 16 (1,0)^{c)}</td> <td>1,5 </td> </tr> </table> <p>In the conditions applicable to Table 3B delete the words "in some countries" in condition^{a)}.</p> <p>In NOTE 1, applicable to Table 3B, delete the second sentence.</p>	Up to and including 6	0,75 ^{a)}	Over 6 up to and including 10 (0,75) ^{b)}	1,0	Over 10 up to and including 16 (1,0) ^{c)}	1,5	Replaced	N/A
Up to and including 6	0,75 ^{a)}								
Over 6 up to and including 10 (0,75) ^{b)}	1,0								
Over 10 up to and including 16 (1,0) ^{c)}	1,5								
3.3.4	<p>In Table 3D, delete the fourth line: conductor sizes for 10 to 13 A, and replace with the following:</p> <table style="margin-left: 40px;"> <tr> <td>Over 10 up to and including 16 </td> <td>1,5 to 2,5 </td> <td>1,5 to 4 </td> </tr> </table> <p>Delete the fifth line: conductor sizes for 13 to 16 A</p>	Over 10 up to and including 16	1,5 to 2,5	1,5 to 4	Deleted	N/A			
Over 10 up to and including 16	1,5 to 2,5	1,5 to 4							
4.3.13.6 (A1:2010)	<p>Replace the existing NOTE by the following:</p> <p>NOTE Z1 Attention is drawn to:</p> <p>1999/519/EC: Council Recommendation on the limitation of exposure of the general public to electromagnetic fields 0 Hz to 300 GHz, and</p> <p>2006/25/EC: Directive on the minimum health and safety requirements regarding the exposure of workers to risks arising from physical agents (artificial optical radiation).</p>	Replaced	N/A						
	Standards taking into account mentioned Recommendation and Directive which demonstrate compliance with the applicable EU Directive are indicated in the OJEC.		N/A						

Annex H	<p>Replace the last paragraph of this annex by:</p> <p>At any point 10 cm from the surface of the OPERATOR ACCESS AREA, the dose rate shall not exceed 1 μSv/h (0,1 mR/h) (see NOTE). Account is taken of the background level.</p> <p>Replace the notes as follows:</p> <p>NOTE These values appear in Directive 96/29/Euratom.</p> <p>Delete NOTE 2.</p>	Replaced	N/A
Bibliography	Additional EN standards.		—

ZA	NORMATIVE REFERENCES TO INTERNATIONAL PUBLICATIONS WITH THEIR CORRESPONDING EUROPEAN PUBLICATIONS	—
-----------	--	---

ZB ANNEX (normative)			
SPECIAL NATIONAL CONDITIONS (EN)			
Clause	Requirement + Test	Result - Remark	Verdict
1.2.4.1	In Denmark , certain types of Class I appliances (see 3.2.1.1) may be provided with a plug not establishing earthing conditions when inserted into Danish socket-outlets.	Class III	N/A
1.2.13.14	In Norway and Sweden , for requirements see 1.7.2.1 and 7.3 of this annex.	Class III	N/A
1.5.7.1	In Finland, Norway and Sweden , resistors bridging BASIC INSULATION in CLASS I PLUGGABLE EQUIPMENT TYPE A must comply with the requirements in 1.5.7.1. In addition when a single resistor is used, the resistor must withstand the resistor test in 1.5.7.2.	Class III	N/A
1.5.8	In Norway , due to the IT power system used (see annex V, Figure V.7), capacitors are required to be rated for the applicable line-to-line voltage (230 V).	Class III	N/A
1.5.9.4	In Finland, Norway and Sweden , the third dashed sentence is applicable only to equipment as defined in 6.1.2.2 of this annex.	Class III	N/A

ZB ANNEX (normative)
SPECIAL NATIONAL CONDITIONS (EN)

Clause	Requirement + Test	Result - Remark	Verdict
1.7.2.1	<p>In Finland, Norway and Sweden, CLASS I PLUGGABLE EQUIPMENT TYPE A intended for connection to other equipment or a network shall, if safety relies on connection to protective earth or if surge suppressors are connected between the network terminals and accessible parts, have a marking stating that the equipment must be connected to an earthed mains socket-outlet.</p> <p>The marking text in the applicable countries shall be as follows:</p> <p>In Finland: "Laite on liitettävä suojakoskettimilla varustettuun pistorasiaan"</p> <p>In Norway: "Apparatet må tilkoples jordet stikkontakt"</p> <p>In Sweden: "Apparaten skall anslutas till jordat uttag"</p> <p>In Norway and Sweden, the screen of the cable distribution system is normally not earthed at the entrance of the building and there is normally no equipotential bonding system within the building. Therefore the protective earthing of the building installation need to be isolated from the screen of a cable distribution system.</p> <p>It is however accepted to provide the insulation external to the equipment by an adapter or an interconnection cable with galvanic isolator, which may be provided by e.g. a retailer.</p> <p>The user manual shall then have the following or similar information in Norwegian and Swedish language respectively, depending on in what country the equipment is intended to be used in:</p> <p>"Equipment connected to the protective earthing of the building installation through the mains connection or through other equipment with a connection to protective earthing – and to a cable distribution system using coaxial cable, may in some circumstances create a fire hazard. Connection to a cable distribution system has therefore to be provided through a device providing electrical isolation below a certain frequency range (galvanic isolator, see EN 60728-11)."</p>	Class III	N/A

ZB ANNEX (normative)			
SPECIAL NATIONAL CONDITIONS (EN)			
Clause	Requirement + Test	Result - Remark	Verdict
	<p>NOTE In Norway, due to regulation for installations of cable distribution systems, and in Sweden, a galvanic isolator shall provide electrical insulation below 5 MHz. The insulation shall withstand a dielectric strength of 1,5 kV r.m.s., 50 Hz or 60 Hz, for 1 min.</p> <p>Translation to Norwegian (the Swedish text will also be accepted in Norway): "Utstyr som er koplet til beskyttelsesjord via nettplugg og/eller via annet jordtilkoplede utstyr – og er tilkoplede et kabel-TV nett, kan forårsake brannfare. For å unngå dette skal det ved tilkopling av utstyret til kabel-TV nettet installeres en galvanisk isolator mellom utstyret og kabel-TV nettet." Translation to Swedish: "Utrustning som är kopplad till skyddsjord via jordat vägguttag och/eller via annan utrustning och samtidigt är kopplad till kabel-TV nät kan i vissa fall medföra risk för brand. För att undvika detta skall vid anslutning av utrustningen till kabel-TV nät galvanisk isolator finnas mellan utrustningen och kabel-TV nätet."</p>	Class III	N/A
1.7.5	<p>In Denmark, socket-outlets for providing power to other equipment shall be in accordance with the Heavy Current Regulations, Section 107-2-D1, Standard Sheet DK 1-3a, DK 1-5a or DK 1-7a, when used on Class I equipment. For STATIONARY EQUIPMENT the socket-outlet shall be in accordance with Standard Sheet DK 1-1b or DK 1-5a.</p> <p>For CLASS II EQUIPMENT the socket outlet shall be in accordance with Standard Sheet DKA 1-4a.</p>	Class III	N/A
2.2.4	<p>In Norway, for requirements see 1.7.2.1, 6.1.2.1 and 6.1.2.2 of this annex.</p>	Class III	N/A
2.3.2	<p>In Finland, Norway and Sweden there are additional requirements for the insulation. See 6.1.2.1 and 6.1.2.2 of this annex.</p>	Class III	N/A
2.3.4	<p>In Norway, for requirements see 1.7.2.1, 6.1.2.1 and 6.1.2.2 of this annex.</p>	Class III	N/A
2.6.3.3	<p>In the United Kingdom, the current rating of the circuit shall be taken as 13 A, not 16 A.</p>	Class III	N/A



ZB ANNEX (normative)			
SPECIAL NATIONAL CONDITIONS (EN)			
Clause	Requirement + Test	Result - Remark	Verdict
2.7.1	In the United Kingdom , to protect against excessive currents and short-circuits in the PRIMARY CIRCUIT of DIRECT PLUG-IN EQUIPMENT, tests according to 5.3 shall be conducted, using an external protective device rated 30 A or 32 A. If these tests fail, suitable protective devices shall be included as integral parts of the DIRECT PLUG-IN EQUIPMENT, so that the requirements of 5.3 are met.	Class III	N/A
2.10.5.13	In Finland, Norway and Sweden , there are additional requirements for the insulation, see 6.1.2.1 and 6.1.2.2 of this annex.	Class III	N/A
3.2.1.1	<p>In Switzerland, supply cords of equipment having a RATED CURRENT not exceeding 10 A shall be provided with a plug complying with SEV 1011 or IEC 60884-1 and one of the following dimension sheets:</p> <p>SEV 6532-2.1991 Plug Type 15 3P+N+PE 250/400 V, 10 A</p> <p>SEV 6533-2.1991 Plug Type 11 L+N 250 V, 10 A</p> <p>SEV 6534-2.1991 Plug Type 12 L+N+PE 250 V, 10 A</p> <p>In general, EN 60309 applies for plugs for currents exceeding 10 A. However, a 16 A plug and socket-outlet system is being introduced in Switzerland, the plugs of which are according to the following dimension sheets, published in February 1998:</p> <p>SEV 5932-2.1998: Plug Type 25 , 3L+N+PE 230/400 V, 16 A</p> <p>SEV 5933-2.1998: Plug Type 21, L+N, 250 V, 16A</p> <p>SEV 5934-2.1998: Plug Type 23, L+N+PE .250 V, 16 A</p>	Class III	N/A

ZB ANNEX (normative)			
SPECIAL NATIONAL CONDITIONS (EN)			
Clause	Requirement + Test	Result - Remark	Verdict
3.2.1.1	<p>In Denmark, supply cords of single-phase equipment having a rated current not exceeding 13 A shall be provided with a plug according to the Heavy Current Regulations, Section 107-2-D1.</p> <p>CLASS I EQUIPMENT provided with socket-outlets with earth contacts or which are intended to be used in locations where protection against indirect contact is required according to the wiring rules shall be provided with a plug in accordance with standard sheet DK 2-1a or DK 2-5a.</p> <p>If poly-phase equipment and single-phase equipment having a RATED CURRENT exceeding 13 A is provided with a supply cord with a plug, this plug shall be in accordance with the Heavy Current Regulations, Section 107-2-D1 or EN 60309-2.</p>	Class III	N/A
3.2.1.1	<p>In Spain, supply cords of single-phase equipment having a rated current not exceeding 10 A shall be provided with a plug according to UNE 20315:1994.</p> <p>Supply cords of single-phase equipment having a rated current not exceeding 2,5 A shall be provided with a plug according to UNE-EN 50075:1993.</p> <p>CLASS I EQUIPMENT provided with socket-outlets with earth contacts or which are intended to be used in locations where protection against indirect contact is required according to the wiring rules, shall be provided with a plug in accordance with standard UNE 20315:1994.</p> <p>If poly-phase equipment is provided with a supply cord with a plug, this plug shall be in accordance with UNE-EN 60309-2.</p>	Class III	N/A
3.2.1.1	<p>In the United Kingdom, apparatus which is fitted with a flexible cable or cord and is designed to be connected to a mains socket conforming to BS 1363 by means of that flexible cable or cord and plug, shall be fitted with a 'standard plug' in accordance with Statutory Instrument 1768:1994 - The Plugs and Sockets etc. (Safety) Regulations 1994, unless exempted by those regulations.</p> <p>NOTE 'Standard plug' is defined in SI 1768:1994 and essentially means an approved plug conforming to BS 1363 or an approved conversion plug.</p>	Class III	N/A



ZB ANNEX (normative)			
SPECIAL NATIONAL CONDITIONS (EN)			
Clause	Requirement + Test	Result - Remark	Verdict
3.2.1.1	In Ireland , apparatus which is fitted with a flexible cable or cord and is designed to be connected to a mains socket conforming to I.S. 411 by means of that flexible cable or cord and plug, shall be fitted with a 13 A plug in accordance with Statutory Instrument 525:1997 - National Standards Authority of Ireland (section 28) (13 A Plugs and Conversion Adaptors for Domestic Use) Regulations 1997.	Class III	N/A
3.2.4	In Switzerland , for requirements see 3.2.1.1 of this annex.	Class III	N/A
3.2.5.1	In the United Kingdom , a power supply cord with conductor of 1,25 mm ² is allowed for equipment with a rated current over 10 A and up to and including 13 A.	Class III	N/A
3.3.4	In the United Kingdom , the range of conductor sizes of flexible cords to be accepted by terminals for equipment with a RATED CURRENT of over 10 A up to and including 13 A is: • 1,25 mm ² to 1,5 mm ² nominal cross-sectional area.	Class III	N/A
4.3.6	In the United Kingdom , the torque test is performed using a socket outlet complying with BS 1363 part 1:1995, including Amendment 1:1997 and Amendment 2:2003 and the plug part of DIRECT PLUG-IN EQUIPMENT shall be assessed to BS 1363: Part 1, 12.1, 12.2, 12.3, 12.9, 12.11, 12.12, 12.13, 12.16 and 12.17, except that the test of 12.17 is performed at not less than 125 °C. Where the metal earth pin is replaced by an Insulated Shutter Opening Device (ISOD), the requirements of clauses 22.2 and 23 also apply.	Class III	N/A
4.3.6	In Ireland , DIRECT PLUG-IN EQUIPMENT is known as plug similar devices. Such devices shall comply with Statutory Instrument 526:1997 - National Standards Authority of Ireland (Section 28) (Electrical plugs, plug similar devices and sockets for domestic use) Regulations, 1997.	Class III	N/A

ZB ANNEX (normative)			
SPECIAL NATIONAL CONDITIONS (EN)			
Clause	Requirement + Test	Result - Remark	Verdict
5.1.7.1	<p>In Finland, Norway and Sweden TOUCH CURRENT measurement results exceeding 3,5 mA r.m.s. are permitted only for the following equipment:</p> <ul style="list-style-type: none"> • STATIONARY PLUGGABLE EQUIPMENT TYPE A that is intended to be used in a RESTRICTED ACCESS LOCATION where equipotential bonding has been applied, for example, in a telecommunication centre; and has provision for a permanently connected PROTECTIVE EARTHING CONDUCTOR; and is provided with instructions for the installation of that conductor by a SERVICE PERSON; • STATIONARY PLUGGABLE EQUIPMENT TYPE B; • STATIONARY PERMANENTLY CONNECTED EQUIPMENT. 	Class III	N/A
6.1.2.1 (A1:2010)	<p>In Finland, Norway and Sweden, add the following text between the first and second paragraph of the compliance clause:</p> <p>If this insulation is solid, including insulation forming part of a component, it shall at least consist of either</p> <ul style="list-style-type: none"> - two layers of thin sheet material, each of which shall pass the electric strength test below, or - one layer having a distance through insulation of at least 0,4 mm, which shall pass the electric strength test below. <p>Alternatively for components, there is no distance through insulation requirements for the insulation consisting of an insulating compound completely filling the casing, so that CLEARANCES and CREEPAGE DISTANCES do not exist, if the component passes the electric strength test in accordance with the compliance clause below and in addition</p> <ul style="list-style-type: none"> - passes the tests and inspection criteria of 2.10.11 with an electric strength test of 1,5 kV multiplied by 1,6 (the electric strength test of 2.10.10 shall be performed using 1,5 kV), and - is subject to ROUTINE TESTING for electric strength during manufacturing, using a test voltage of 1,5 kV. 	Class III	N/A

ZB ANNEX (normative)			
SPECIAL NATIONAL CONDITIONS (EN)			
Clause	Requirement + Test	Result - Remark	Verdict
	<p>It is permitted to bridge this insulation with an optocoupler complying with 2.10.5.4 b).</p> <p>It is permitted to bridge this insulation with a capacitor complying with EN 60384-14:2005, subclass Y2.</p> <p>A capacitor classified Y3 according to EN 60384-14:2005, may bridge this insulation under the following conditions:</p> <ul style="list-style-type: none"> - the insulation requirements are satisfied by having a capacitor classified Y3 as defined by EN 60384-14, which in addition to the Y3 testing, is tested with an impulse test of 2,5 kV defined in EN 60950-1:2006, 6.2.2.1; - the additional testing shall be performed on all the test specimens as described in EN 60384-14: - the impulse test of 2,5 kV is to be performed before the endurance test in EN 60384-14, in the sequence of tests as described in EN 60384-14. 	Class III	N/A
6.1.2.2	<p>In Finland, Norway and Sweden, the exclusions are applicable for PERMANENTLY CONNECTED EQUIPMENT, PLUGGABLE EQUIPMENT TYPE B and equipment intended to be used in a RESTRICTED ACCESS LOCATION where equipotential bonding has been applied, e.g. in a telecommunication centre, and which has provision for a permanently connected PROTECTIVE EARTHING CONDUCTOR and is provided with instructions for the installation of that conductor by a SERVICE PERSON.</p>	Class III	N/A
7.2	<p>In Finland, Norway and Sweden, for requirements see 6.1.2.1 and 6.1.2.2 of this annex.</p> <p>The term TELECOMMUNICATION NETWORK in 6.1.2 being replaced by the term CABLE DISTRIBUTION SYSTEM.</p>	No such connection	N/A
7.3	<p>In Norway and Sweden, for requirements see 1.2.13.14 and 1.7.2.1 of this annex.</p>	As above	N/A
7.3	<p>In Norway, for installation conditions see EN 60728-11:2005.</p>		N/A



**ATTACHMENT TO TEST REPORT IEC 60950-1
FINLAND NATIONAL DIFFERENCES**

Information technology equipment – Safety –

Part 1: General requirements

Differences according to: EN 60950-1:2006/A11:2009/A1:2010

Attachment Form No.: FI_ND_IEC60950_1C

Attachment Originator: SGS Fimko Ltd

Master Attachment: Date (2010-04)

Copyright © 2010 IEC System for Conformity Testing and Certification of Electrical Equipment (IECEE), Geneva, Switzerland. All rights reserved.

	National Differences		P
General	See also Group Differences (EN 60950-1:2006/A11/A1)		P
1.5.7.1	In Finland resistors bridging BASIC INSULATION in CLASS I PLUGGABLE EQUIPMENT TYPE A must comply with the requirements in 1.5.7.1. In addition when a single resistor is used, the resistor must withstand the resistor test in 1.5.7.2.	Class III	N/A
1.5.9.4	In Finland , the third dashed sentence is applicable only to equipment as defined in 6.1.2.2 of this annex.	Class III	N/A
1.7.2.1	In Finland , CLASS I PLUGGABLE EQUIPMENT TYPE A intended for connection to other equipment or a network shall, if safety relies on connection to protective earth or if surge suppressors are connected between the network terminals and accessible parts, have a marking stating that the equipment must be connected to an earthed mains socket-outlet. The marking text in in Finland shall be as follows: "Laite on liitettävä suojakoskettimilla varustettuun pistorasiaan"	Class III	N/A
2.3.2	In Finland , there are additional requirements for the insulation. See 6.1.2.1 and 6.1.2.2 of this annex.	Class III	N/A
2.10.5.13	In Finland , there are additional requirements for the insulation, see 6.1.2.1 and 6.1.2.2 of this annex.	Class III	N/A

<p>5.1.7.1</p>	<p>In Finland, TOUCH CURRENT measurement results exceeding 3,5 mA r.m.s. are permitted only for the following equipment:</p> <ul style="list-style-type: none"> • STATIONARY PLUGGABLE EQUIPMENT TYPE A that <ul style="list-style-type: none"> - is intended to be used in a RESTRICTED ACCESS LOCATION where equipotential bonding has been applied, for example, in a telecommunication centre; and - has provision for a permanently connected PROTECTIVE EARTHING CONDUCTOR; and - is provided with instructions for the installation of that conductor by a SERVICE PERSON; • STATIONARY PLUGGABLE EQUIPMENT TYPE B; • STATIONARY PERMANENTLY CONNECTED EQUIPMENT. 	<p>Class III</p>	<p>N/A</p>
<p>6.1.2.1 (A1:2010)</p>	<p>In Finland, add the following text between the first and second paragraph of the compliance clause:</p> <p>If this insulation is solid, including insulation forming part of a component, it shall at least consist of either</p> <ul style="list-style-type: none"> - two layers of thin sheet material, each of which shall pass the electric strength test below, or - one layer having a distance through insulation of at least 0,4 mm, which shall pass the electric strength test below. <p>Alternatively for components, there is no distance through insulation requirement for the insulation consisting of an insulating compound completely filling the casing, so that CLEARANCES and CREEPAGE DISTANCES do not exist, if the component passes the electric strength test in accordance with the compliance clause below and in addition</p> <ul style="list-style-type: none"> - passes the tests and inspection criteria of 2.10.11 with an electric strength test of 1,5 kV multiplied by 1,6 (the electric strength test of 2.10.10 shall be performed using 1,5 kV), and - is subject to ROUTINE TESTING for electric strength during manufacturing, using a test voltage of 1,5 kV. 	<p>Class III</p>	<p>N/A</p>

	<p>It is permitted to bridge this insulation with an optocoupler complying with 2.10.5.4 b).</p> <p>It is permitted to bridge this insulation with a capacitor complying with EN 60384-14:2005, subclass Y2.</p> <p>A capacitor classified Y3 according to EN 60384-14:2005, may bridge this insulation under the following conditions:</p> <ul style="list-style-type: none"> - the insulation requirements are satisfied by having a capacitor classified Y3 as defined by EN 60384-14:2005 which in addition to the Y3 testing, is tested with an impulse test of 2,5 kV defined in EN 60950-1:2006, 6.2.2.1; - the additional testing shall be performed on all the test specimens as described in EN 60384-14:2005; - the impulse test of 2,5 kV is to be performed before the endurance test in EN 60384-14:2005, in the sequence of tests as described in EN 60384-14:2005. 	Class III	N/A
6.1.2.2	<p>In Finland, the exclusions are applicable for PERMANENTLY CONNECTED EQUIPMENT, PLUGGABLE EQUIPMENT TYPE B and equipment intended to be used in a RESTRICTED ACCESS LOCATION where equipotential bonding has been applied, e.g. in a telecommunication centre, and which has provision for a permanently connected PROTECTIVE EARTHING CONDUCTOR and is provided with instructions for the installation of that conductor by a SERVICE PERSON.</p>	Class III	N/A
7.2	<p>In Finland, for requirements see 6.1.2.1 and 6.1.2.2 of this annex.</p> <p>The term TELECOMMUNICATION NETWORK in 6.1.2 being replaced by the term CABLE DISTRIBUTION SYSTEM.</p>	Class III	N/A



ATTACHMENT TO TEST REPORT IEC 60950-1 FINLAND NATIONAL DIFFERENCES Information technology equipment – Safety –	
Part 1: General requirements	
Differences according to	EN 60950-1:2006/A11:2009/A1:2010
Attachment Form No.	FI_ND_IEC60950_1C
Attachment Originator	SGS Fimko Ltd
Master Attachment	Date (2010-04)
Copyright © 2010 IEC System for Conformity Testing and Certification of Electrical Equipment (IECEE), Geneva, Switzerland. All rights reserved.	

	National Differences		P
General	See also Group Differences (EN 60950-1:2006/A11/A1)		P
1.5.7.1	In Finland resistors bridging BASIC INSULATION in CLASS I PLUGGABLE EQUIPMENT TYPE A must comply with the requirements in 1.5.7.1. In addition when a single resistor is used, the resistor must withstand the resistor test in 1.5.7.2.	Class III	N/A
1.5.9.4	In Finland , the third dashed sentence is applicable only to equipment as defined in 6.1.2.2 of this annex.	Class III	N/A
1.7.2.1	In Finland , CLASS I PLUGGABLE EQUIPMENT TYPE A intended for connection to other equipment or a network shall, if safety relies on connection to protective earth or if surge suppressors are connected between the network terminals and accessible parts, have a marking stating that the equipment must be connected to an earthed mains socket-outlet. The marking text in in Finland shall be as follows: "Laite on liitettävä suojakoskettimilla varustettuun pistorasiaan"	Class III	N/A
2.3.2	In Finland , there are additional requirements for the insulation. See 6.1.2.1 and 6.1.2.2 of this annex.	Class III	N/A
2.10.5.13	In Finland , there are additional requirements for the insulation, see 6.1.2.1 and 6.1.2.2 of this annex.	Class III	N/A



5.1.7.1	<p>In Finland, TOUCH CURRENT measurement results exceeding 3,5 mA r.m.s. are permitted only for the following equipment:</p> <ul style="list-style-type: none"> • STATIONARY PLUGGABLE EQUIPMENT TYPE A that <ul style="list-style-type: none"> - is intended to be used in a RESTRICTED ACCESS LOCATION where equipotential bonding has been applied, for example, in a telecommunication centre; and - has provision for a permanently connected PROTECTIVE EARTHING CONDUCTOR; and - is provided with instructions for the installation of that conductor by a SERVICE PERSON; • STATIONARY PLUGGABLE EQUIPMENT TYPE B; • STATIONARY PERMANENTLY CONNECTED EQUIPMENT. 	Class III	N/A
6.1.2.1 (A1:2010)	<p>In Finland, add the following text between the first and second paragraph of the compliance clause:</p> <p>If this insulation is solid, including insulation forming part of a component, it shall at least consist of either</p> <ul style="list-style-type: none"> - two layers of thin sheet material, each of which shall pass the electric strength test below, or - one layer having a distance through insulation of at least 0,4 mm, which shall pass the electric strength test below. <p>Alternatively for components, there is no distance through insulation requirement for the insulation consisting of an insulating compound completely filling the casing, so that CLEARANCES and CREEPAGE DISTANCES do not exist, if the component passes the electric strength test in accordance with the compliance clause below and in addition</p> <ul style="list-style-type: none"> - passes the tests and inspection criteria of 2.10.11 with an electric strength test of 1,5 kV multiplied by 1,6 (the electric strength test of 2.10.10 shall be performed using 1,5 kV), and - is subject to ROUTINE TESTING for electric strength during manufacturing, using a test voltage of 1,5 kV. 	Class III	N/A

	<p>It is permitted to bridge this insulation with an optocoupler complying with 2.10.5.4 b).</p> <p>It is permitted to bridge this insulation with a capacitor complying with EN 60384-14:2005, subclass Y2.</p> <p>A capacitor classified Y3 according to EN 60384-14:2005, may bridge this insulation under the following conditions:</p> <ul style="list-style-type: none"> - the insulation requirements are satisfied by having a capacitor classified Y3 as defined by EN 60384-14:2005 which in addition to the Y3 testing, is tested with an impulse test of 2,5 kV defined in EN 60950-1:2006, 6.2.2.1; - the additional testing shall be performed on all the test specimens as described in EN 60384-14:2005; - the impulse test of 2,5 kV is to be performed before the endurance test in EN 60384-14:2005, in the sequence of tests as described in EN 60384-14:2005. 	Class III	N/A
6.1.2.2	<p>In Finland, the exclusions are applicable for PERMANENTLY CONNECTED EQUIPMENT, PLUGGABLE EQUIPMENT TYPE B and equipment intended to be used in a RESTRICTED ACCESS LOCATION where equipotential bonding has been applied, e.g. in a telecommunication centre, and which has provision for a permanently connected PROTECTIVE EARTHING CONDUCTOR and is provided with instructions for the installation of that conductor by a SERVICE PERSON.</p>	Class III	N/A
7.2	<p>In Finland, for requirements see 6.1.2.1 and 6.1.2.2 of this annex.</p> <p>The term TELECOMMUNICATION NETWORK in 6.1.2 being replaced by the term CABLE DISTRIBUTION SYSTEM.</p>	Class III	N/A



National Differences/EU Special National Conditions/EU A-Deviations for Switzerland (CH) (EN 60950-1:2006/AC:2011)			P
1.5.1	Switzerland (Ordinance on environmentally hazardous substances SR 814.081, Annex 1.7, Mercury - Annex 1.7 of SR 814.81 applies for mercury.) Add the following: NOTE In Switzerland, switches containing mercury such as thermostats, relays and level controllers are not allowed.		P
1.7.13	Switzerland (Ordinance on chemical hazardous risk reduction SR 814.81, Annex 2.15 Batteries) Annex 2.15 of SR 814.81 applies for batteries.	Certified batteries ate used	P
3.2.1.1	In Switzerland, supply cords of equipment having a RATED CURRENT not exceeding 10 A shall be provided with a plug complying with SEV 1011 or IEC 60884-1 and one of the following dimension sheets: SEV 6532-2.1991 Plug Type 15 3P+N+PE 250/400 V, 10 A SEV 6533-2.1991 Plug Type 11 L+N 250 V, 10 A SEV 6534-2.1991 Plug Type 12 L+N+PE 250 V, 10 A In general, EN 60309 applies for plugs for currents exceeding 10 A. However, a 16 A plug and socket-outlet system is being introduced in Switzerland, the plugs of which are according to the following dimension sheets, published in February 1998: SEV 5932-2.1998 Plug Type 25 3L+N+PE 230/400 V, 16 A SEV 5933-2.1998 Plug Type 21 L+N 250 V, 16 A SEV 5934-2.1998 Plug Type 23 L+N+PE 250 V, 16 A	Class III	N/A
3.2.4	In Switzerland, for requirements see 3.2.1.1 of this annex.	Class III	N/A

National Differences/EU A-Deviations for Germany (DE)	P
--	---



1.7.2.1	According to GPSG, section 2, clause 4: If certain rules on the use, supplementation or maintenance of an item of technical work equipment or ready-to-use commodity must be observed in order to guarantee safety and health, instructions for use in German must be supplied when it is brought into circulation.	Class III	N/A
---------	--	-----------	-----

End of test report